

TECHNICAL MANUAL

ORGANIZATIONAL MAINTENANCE

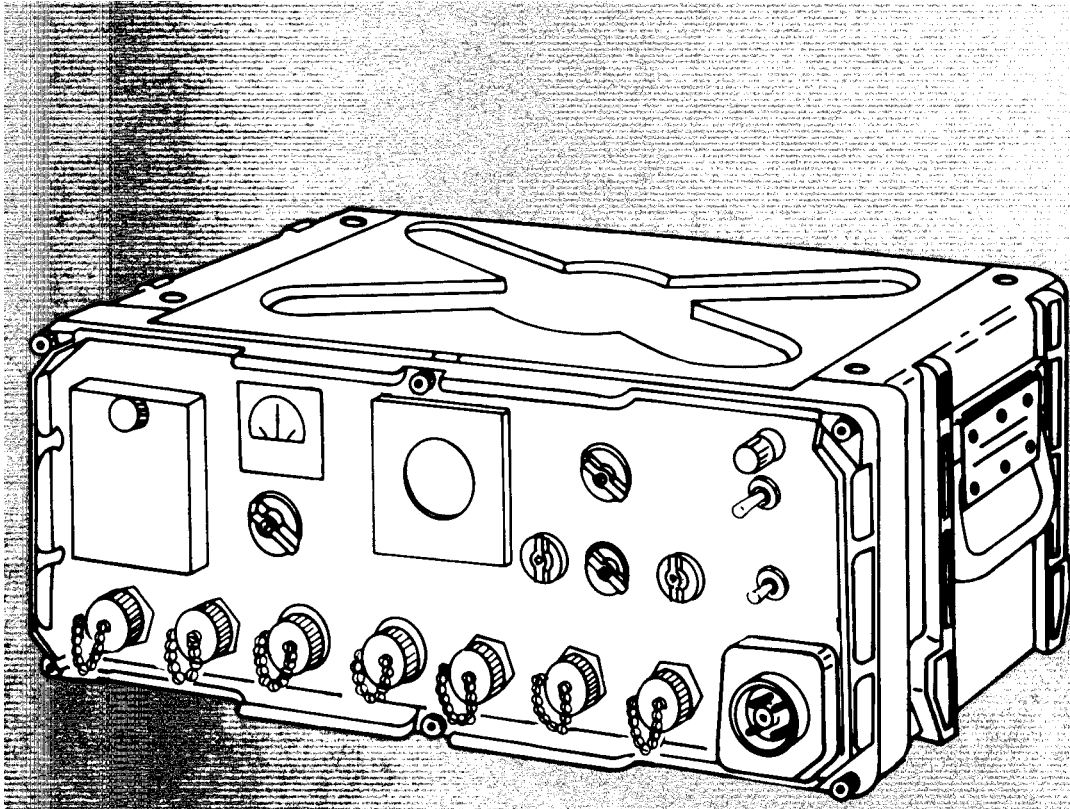

**MAINTENANCE  
INSTRUCTIONS**  
Page 2-0

**SERVICE  
UPON RECEIPT**  
Page 2-1

**PREVENTIVE  
MAINTENANCE  
CHECKS & SERVICES**  
Page 2-7

**TROUBLESHOOTING**  
Page 2-13

**MAINTENANCE  
PROCEDURES**  
Page 2-20

**PREPARATION FOR  
STORAGE & SHIPMENT**  
Page 2-25

**MODEM RADIO TELETYPEWRITER**

**MD-522A/R C**  
**(NSN 5815-00-919-4800)**

**HEADQUARTERS, DEPARTMENT OF THE ARMY**

5 APRIL 1984





## **5** SAFETY STEPS TO FOLLOW IF SOMEONE IS THE VICTIM OF ELECTRICAL SHOCK

**1** DO NOT TRY TO PULL OR GRAB THE INDIVIDUAL

**2** IF POSSIBLE, TURN OFF THE ELECTRICAL POWER

**3** IF YOU CANNOT TURN OFF THE ELECTRICAL POWER, PULL, PUSH, OR LIFT THE PERSON TO SAFETY USING A WOODEN POLE OR A ROPE OR SOME OTHER INSULATING MATERIAL

**4** SEND FOR HELP AS SOON AS POSSIBLE

**5** AFTER THE INJURED PERSON IS FREE OF CONTACT WITH THE SOURCE OF ELECTRICAL SHOCK, MOVE THE PERSON A SHORT DISTANCE AWAY AND IMMEDIATELY START ARTIFICIAL RESUSCITATION

WARNING

Be careful when working on this equipment. Serious injury or DEATH may result from contact with these terminals.

DON'T TAKE CHANCES!

HIGH VOLTAGES EXIST IN THE FOLLOWING EQUIPMENT:

Various connectors and power supply components. . . . .	27 vdc
DC LOOP NO. 1 and DC LOOP NO. 2 connectors . . . . .	120 vdc
Loop battery module A5 . . . . .	127 vdc
Scope module A2 . . . . .	1,100vdc

Set ON/OFF circuit breaker switch on front panel of MD-522A/GRC to OFF before removing chassis to inspect this equipment.

WARNING

SAFETY PRECAUTION

A periodic review of safety precautions in TB 385-4, Safety Precautions for Maintenance of Electrical/Electronic Equipment, is recommended. When the equipment is operated with covers removed, do not touch exposed connections or components. Make certain you are not grounded when making connections or adjusting components inside the test instruments.

WARNING

Adhesive/cement P/N EC-847 NSN 8040-00-691-6134 fumes are toxic. Avoid breathing fumes, and avoid contact with skin. Provide adequate ventilation.

WARNING

Adequate ventilation should be provided while using TRICHLOROTRIFLUOROETHANE. Prolonged breathing of vapor should be avoided. The solvent should not be used near heat or open flame, the products of decomposition are toxic and irritating. Since TRICHLOROTRIFLUOROETHANE dissolves natural oils, prolonged contact with skin should be avoided. When necessary use gloves which the solvent cannot penetrate. If the solvent is taken internally, consult a physician.

WARNING

Compressed air shall not be used for cleaning purposes except where reduced to less than 29 psi and then only with effective chip guarding and personnel protective equipment. Do not use compressed air to dry parts when TRICHLOROTRIFLUOROETHANE has been used. Compressed air is dangerous and can cause serious bodily harm if protective means or methods are not observed to prevent chip or particle (of whatever size) from being blown into the eyes or unbroken skin of the operator or other personnel.

WARNING  
RADIATION HAZARD

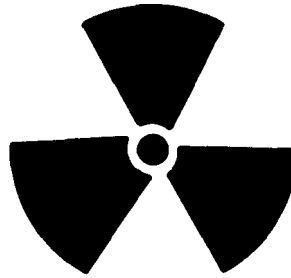

RADIOACTIVE MATERIAL  
CONTROLLED DISPOSAL REQUIRED  
ACCOUNTABILITY NOT REQUIRED

Meter . . . . . Ra 226 . . . . . 1.OuCi . . . . . 6625-00-257-1103

Radiation Hazard Information: The following radiation hazard information must be read and understood by all personnel operating or repairing MODEM, MD-522A/GRC. Hazardous radioactive materials are present in the above listed component of the MD-522A/GRC. The component is potentially hazardous when broken. See qualified medical personnel and the local Radiological Protection Officer (RPO) immediately if you are exposed to or cut by broken components. First aid instructions are contained in TB 43-0116, TB 43-0122, and AR 385-11.

NEVER place radioactive components in your pocket. Use extreme care NOT to break radioactive components while handling them.

NEVER remove radioactive components from cartons until you are ready to use them.

If any of these components are broken, notify the local RPO immediately.

The RPO will survey the immediate area for radiological contamination and will supervise the removal of broken components.

The above listed radioactive components will NOT be repaired or disassembled.

Disposal of broken, unserviceable, or unwanted radioactive components will be accomplished in accordance with the instructions in AR 385-11.



TECHNICAL MANUAL

No. 11-5805-387-20-2

HEADQUARTERS  
DEPARTMENT OF THE ARMY

Washington, DC, 5 April 1984

ORGANIZATIONAL MAINTENANCE MANUAL  
MODEM RADIO TELETYPEWRITER  
MD-522A/GRC (NSN 5815-00-919-4800)

REPORTING OF ERRORS AND RECOMMENDING IMPROVEMENTS

You can help improve this manual. If you find any mistakes or if you know of a way to improve the procedures, please let us know. Mail your letter, DA Form 2028 (Recommended Changes to Publications and Blank Forms), or DA Form 2028-2 located in back of this manual direct to: Commander, US Army Communications-Electronics Command and Fort Monmouth, ATTN: DRSEL-ME-MP, Fort Monmouth, New Jersey 07703. In either case, a reply will be furnished to you.

	PAGE
CHAPTER 1 INTRODUCTION .....	1-1
Section I. General information .....	1-1
II. Equipment Description and Data.....	1-2
III. Technical Principles of Operation .....	1-2
CHAPTER 2 <b>MAINTENANCE INSTRUCTIONS</b> .....	2-0
Section I. <b>Repair Parts, Special Tools, and Support Equipment</b> .....	2-1
II. <b>Service Upon Receipt</b> .....	2-1
III. <b>Preventive Maintenance Checks and Services (PMCS)</b> .....	2-7
IV. <b>Troubleshooting</b> .....	2-13
V. <b>Maintenance Procedures</b> .....	2-20
VI. <b>Preparation for Storage and Shipment</b> .....	2-26
APPENDIX A REFERENCES .....	A-1
B MAINTENANCE ALLOCATION CHART (MAC) .....	B-3
C EXPENDABLE SUPPLIES AND MATERIALS LIST .....	C-1
GLOSSARY .....	G-1
INDEX .....	I-1

\*This manual supersedes the organizational maintenance portion of TM 11-5805-387 -15-1,6 June 1967, including all changes.

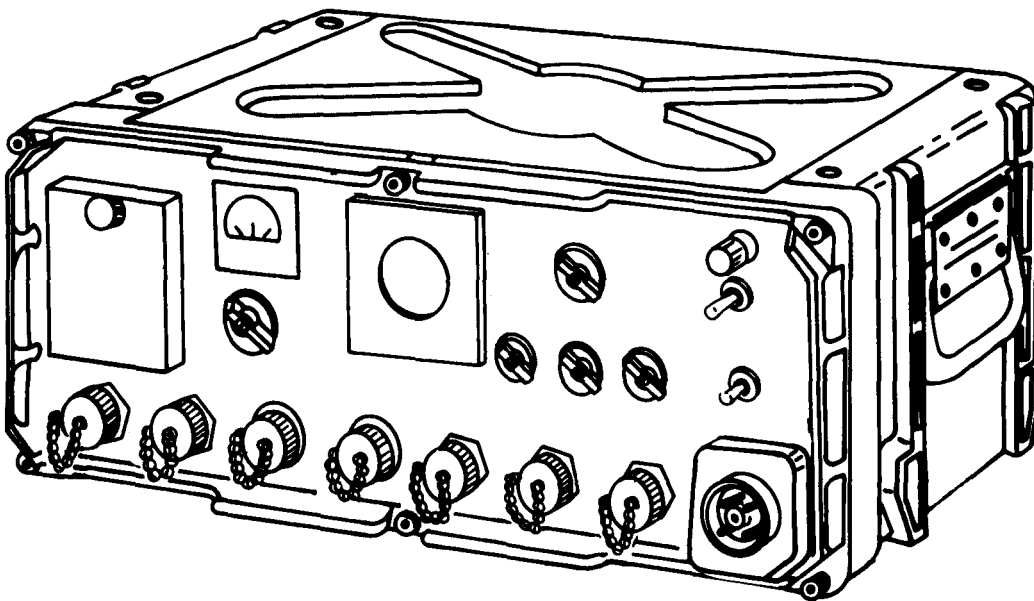

MODEM RADIO TELETYPEWRITER MD-522A/GRC



## CHAPTER 1 INTRODUCTION

---

### Section I. GENERAL INFORMATION

#### 1-1. SCOPE

- Type of Manual: Organizational Maintenance
- Model Number and Equipment Name: Modem Radio Teletypewriter MD-522A/GRC
- Purpose of Equipment: Permits transmission and/or reception (transception) of teletypewriter data and voice communications.

#### 1-2. CONSOLIDATED INDEX OF ARMY PUBLICATIONS AND BLANK FORMS

Refer to the latest issue of DA PAM 310-1 to determine whether there are new editions, changes or additional publications pertaining to the equipment.

#### 1-3. MAINTENANCE FORMS, RECORDS, AND REPORTS

##### a. Reports of Maintenance and Unsatisfactory Equipment.

Department of the Army forms and procedures used for equipment maintenance will be those prescribed by DA Pam 738-750 as contained in Maintenance Management Update.

##### b. Report of Packaging and Handling Deficiencies.

Fill out and forward SF 364 (Report of Discrepancy (ROD)) as prescribed in AR 735-11-2/DLAR 4140.55/NAVMATINST 4355.73A/AFR 400-54/MCO 4430.3F.

##### c. Discrepancy in Shipment Report (DISREP) (SF 361).

Fill out and forward Discrepancy in Shipment Report (DISREP) (SF 361) as prescribed in AR 55-38/NAVSUPINST 4610.33C/AFR 75-18/MCO P4610.19D/DLAR 4500.15.

#### 1-4. DESTRUCTION OF ARMY ELECTRONICS MATERIEL

Destruction of Army electronics materiel to prevent enemy use shall be in accordance with TM 750-244-2.

#### 1-5. ADMINISTRATIVE STORAGE

Administrative Storage of Equipment issued to and used by Army activities will have preventive maintenance performed in accordance with the PMCS charts (page 2-10) before storing. When removing the equipment from administrative storage, the PMCS should be performed to assure operational readiness. Disassembly and repacking of equipment for shipment or limited storage are covered in chapter 2, section VI of this manual.

#### 1-6. REPORTING EQUIPMENT IMPROVEMENT RECOMMENDATIONS (EIR'S)

If your Modem Radio Teletypewriter MD-522A/GRC needs improvement, let us know. Send us an EIR. You, the user, are the only one who can tell us what you don't like about your equipment. Let us know why you don't like the design. Tell us why a procedure is hard to perform. Put it on an SF 368 (Quality Deficiency Report). Mail it to Commander, US Army Communications-Electronics Command and Fort Monmouth, ATTN: DRSEL-ME-MP, Fort Monmouth, New Jersey 07703. We'll send you a reply.

## 1-7. NOMENCLATURE CROSS-REFERENCE

### COMMON NAME

Modem

### OFFICIAL NOMENCLATURE

Modem Radio Teletypewriter MD-522A/GRC

### NOTE

Official nomenclature must be used when filling out report forms onlooking up technical manuals.

## Section II. EQUIPMENT DESCRIPTION AND DATA

### 1-8. EQUIPMENT CHARACTERISTICS, CAPABILITIES AND FEATURES

Refer to Operator's Manual TM 11-5805-387-10-2.

### 1-9. LOCATION AND DESCRIPTION OF MAJOR COMPONENTS

Refer to Operator's Manual TM 11-5805-387-10-2.

### 1-10. EQUIPMENT DATA

Refer to Operator's Manual TM 11-5805-387-10-2.

### 1-11. SAFETY, CARE AND HANDLING

Observe all WARNINGS, CAUTIONS and NOTES in this manual. This equipment can be extremely dangerous if these instructions are not followed.

## Section III. TECHNICAL PRINCIPLES OF OPERATION

### 1-12. TECHNICAL PRINCIPLES OF OPERATION

When the modem is used as part of a radio teletypewriter system (fig. 1-1), its modulator section accepts current pulses in a standard code from a sending teletypewriter and converts them into audio tones; its demodulator section receives audio tones from an external source and changes them into current pulses which operate a receiving teletypewriter. As part of a landline teletypewriter system (fig. 1-2), the modem functions the same as described above. However, incoming and outgoing signals can be received from, or applied to, telephone isolation amplifiers rather than radio equipment. As part of a pony circuit setup (fig. 1-3), the modem provides teletypewriter communications between the local receiving teletypewriter base and a remote (pony) teletypewriter.

### NOTE

See TM 11-5805-367-34-2 for more extensive explanations on principle of operation.

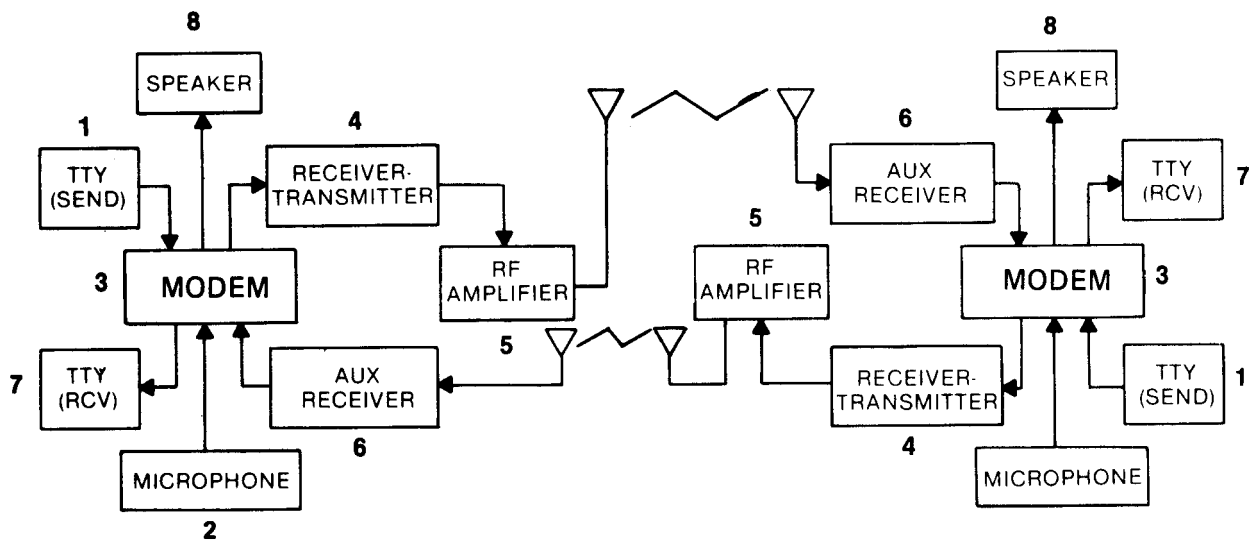

**FIGURE 1-1. MODEM: TYPICAL CONFIGURATION FOR DUPLEX RADIO TELETYPEWRITER SYSTEM**

- 1 Teletypewriter [tty (SEND)] dc mark and space pulses are sensed by the modem.
- 2 The modem also senses voice signals from microphone.
- 3 Teletypewriter dc pulses are converted to tty tones and combined with voice signals by the modem.
- 4 These combined tty tones and voice signals are applied to a receiver-transmitter, and converted to an rf signal.
- 5 This rf signal is then applied to an rf amplifier for transmission. The amplified rf signal is applied to an antenna and sent to a distant station.
- 6 When received, rf signals are processed by an aux (auxiliary) receiver and applied to the modem. The signals are separated and converted into voice signals and tty mark and space pulses.
- 7 The tty pulses are applied to a teletypewriter [tty (RCV)] and then applied to page printers or tape punches for message interpretation.
- 8 An audio output can be applied to speaker for local use.

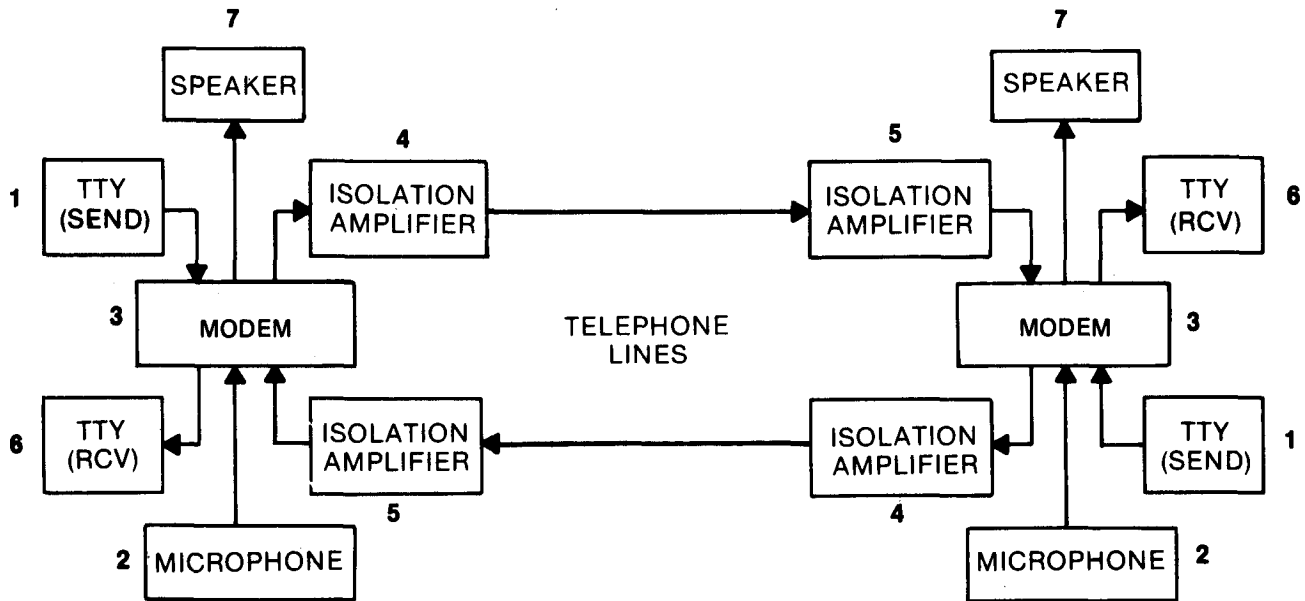

**FIGURE 1-2. MODEM: TYPICAL CONFIGURATION FOR DUPLEX LANDLINE (600 OHMS) TELETYPEWRITER SYSTEM**

- 1 Teletypewriter [tty (SEND)] dc mark and space pulses are sensed by the modem.
- 2 Voice signals from the microphone are routed through the modem for switching purposes.
- 3 The modem converts the tty SEND mark and space pulses to tty tones.
- 4 These tones and voice signals are applied to an isolation amplifier, which provides impedance matching for transmission over telephone lines to a distant station.
- 5 When received, an isolation amplifier again provides impedance matching. The received signals are applied to the modem. The tty tones are converted into tty dc pulses.
- 6 The tty pulses are applied to a teletypewriter [tty (RCV)] and applied to page printers or tape punches for message interpretation.
- 7 An audio output can be applied to a speaker for local use.

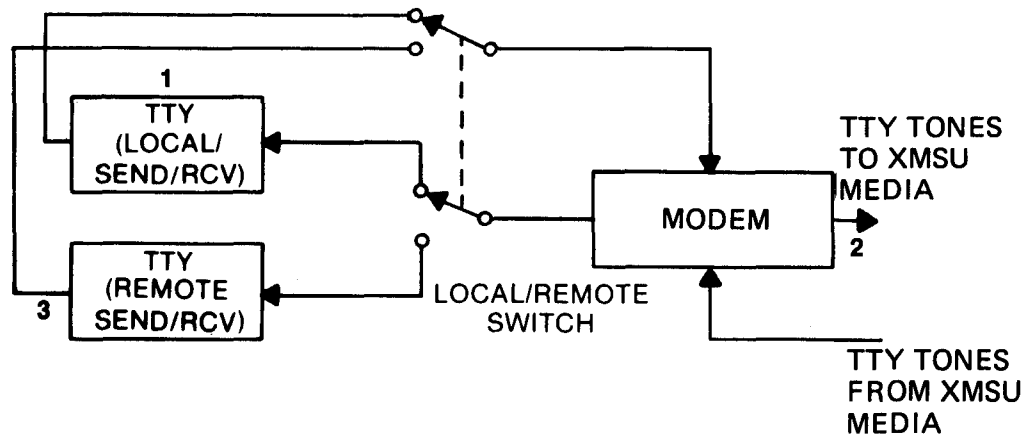

FIGURE 1-3. MODEM: TYPICAL CONFIGURATION FOR PONY OPERATION

- 1 Teletypewriter (local or remote send) dc mark and space pulses are sensed by the modem.
- 2 The modem converts tty dc pulses to tty tones for transmission.
- 3 With LOCAL-REMOTE switch on control panel (AN/GRC-142,-122) or switch assembly (AN/GRC-142A, -142B, -122A, -122B) in REMOTE or LOCAL position, tty dc pulses are sent to [tty (REMOTE)] on local receive circuits and applied to page printers or tape punches for message interpretation.
- 4 Received tty tones are converted by the modem into dc mark and space pulses.

#### NOTE

When connected in the pony circuit configuration, the modem provides local teletypewriter communications between the local receiving teletypewriter base and a remote (pony) teletypewriter located somewhere in the nearby area of the base.

**CHAPTER 2**  
**MAINTENANCE INSTRUCTIONS**

	<b>PAGE</b>
Cleaning .....	2-22
Connections .....	2-3
Installation .....	2-1
Mounting Procedure .....	2-3
Preliminary Servicing and Adjustment:	
Loop Current Internal-External Switch.....	2-6
Transmit NORM/REV Switch.....	2-7
Preparation for Storage or Shipment .....	2-25
PMCS Table .....	2-10
Removing Chassis .....	2-20
Replacing	
Chassis .....	2-24
Front Panel Gasket .....	2-23
Service upon Receipt .....	2-1
Troubleshooting .....	2-13
Unpacking .....	2-1

**Section I. REPAIR PARTS, SPECIAL TOOLS AND SUPPORT EQUIPMENT**

**2-1. TOOLS AND TEST EQUIPMENT**

Tools and test equipment required for organizational maintenance of the modem are listed in the maintenance allocation chart (MAC) in appendix B of this manual.

**2-2. SPECIAL TOOLS, TMDE AND SUPPORT EQUIPMENT**

There are no special tools or TMDE required for organizational maintenance of this equipment. Refer to Organizational Maintenance Repair Parts and Special Tools (RPSTL) manual TM, TM 11-5805-387-20P-1.

**Section II. SERVICE UPON RECEIPT**

**NOTE**

Do not unpack modem until you unpack, assemble, install and connect the rack in which it is to be placed.

**2-3. UNPACKING THE MODEM**

ITEM	ACTION	REMARKS
1. Carton	Open	
2. Modem	Unpack	See figure 2-1.
	Inspect for damage done during shipment.	Report any damage on SF 364 Report of Discrepancy (ROD).
	Compare with packing list.	Be sure shipment is complete. Report any differences according to instructions in DA PAM 738-750.
	Check for modifications.	Check on front panel near nomenclature plate for any modification work order (MWO) numbers. They will appear only if the unit has been used or reconditioned. Current MWO's which apply to the modem are listed in DA Pam 310-1. Apply all URGENT MWO's. Schedule all NORMAL MWO's.

**2-4. INSTALLATION INSTRUCTIONS**

**CAUTION**

Choose an installation space for the modem where adequate ventilation is provided for transistor heat dissipation. Do not install unit close to other heat-producing equipment, such as power units and space heaters. Excessive heat will damage the modem.

**a. Tools, Test Equipment and Materials Needed for Installation**

- All tools you will need to install the modem are in Tool Kit, Electronic Equipment TK-101/G.

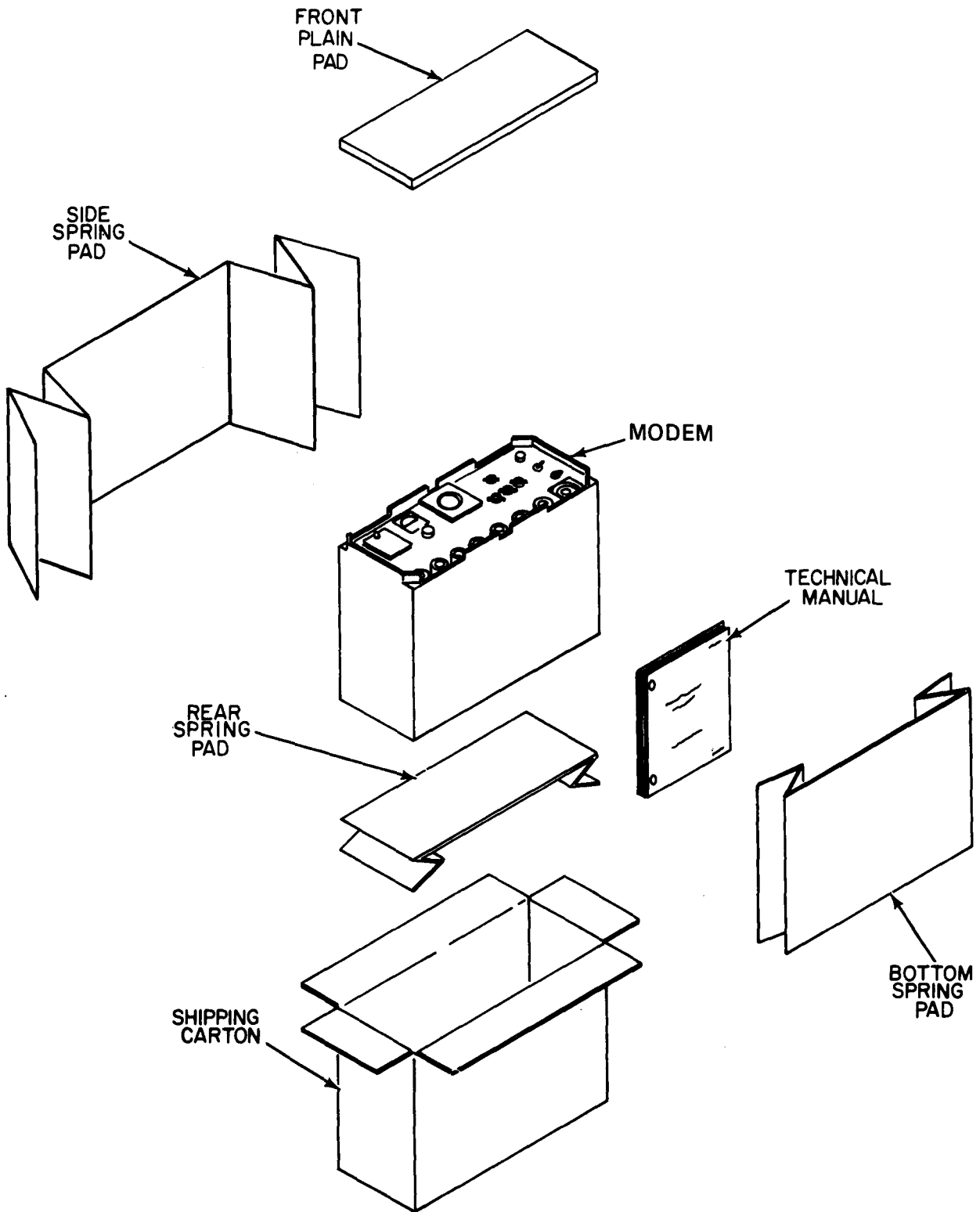
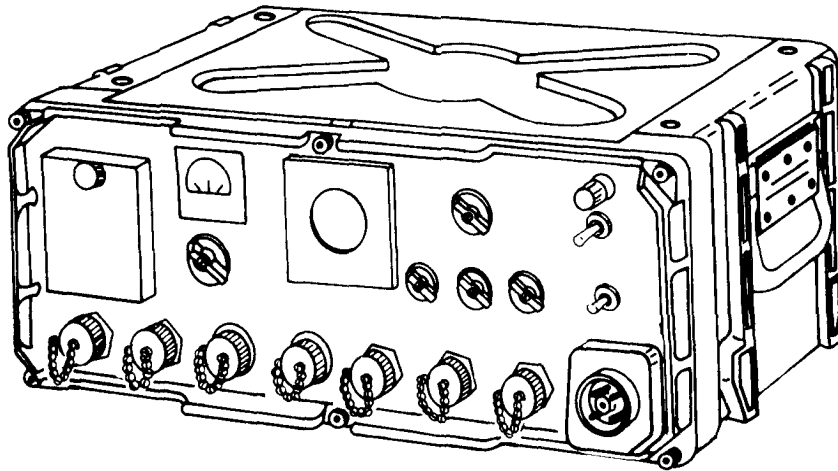

FIGURE 2-1. UNPACKING MD-522A/GRC



## b. Mounting Procedure

- The modem is designed to be used as part of a system, so determine correct installation of the unit by its end use.
- The modem may be installed on a separate mounting base.
- The modem may be stack-mounted with other units of similar case construction. For stack-mounting installation, the modem is equipped with four round indentations.



...and four matching cylindrical cleats on the bottom.

## c. Connections

### CAUTION

Avoid transistor damage by always setting power switch to OFF before making cable connections. Check polarity and measure voltage load of power source before making connections. Transistors may be permanently damaged by improper voltage or polarity.

- Make all necessary external connections to modem at bottom of front panel as determined by system requirements.

### **NOTE**

No connection cables are supplied with modem; you must supply all cables needed for specific connections. See figure 2-2 for detailed information regarding connection of modem in typical equipment configurations.

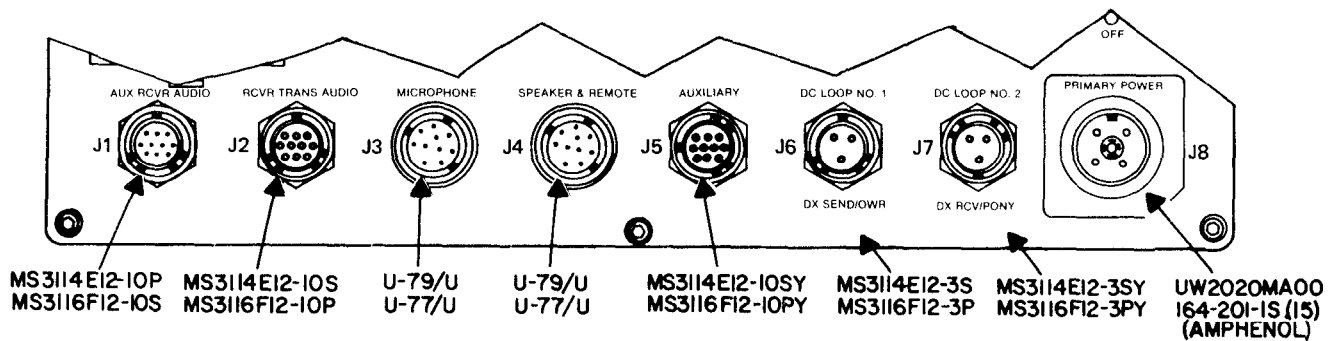

J1 TO AUDIO OUTPUT  
AT AUXILIARY RECEIVER  
(SUCH AS RECEIVER-TRANSMITTER RT-662/GRC)

J2 TO TRANSMITTER AUDIO INPUT AT RADIO SET  
(SUCH AS RADIO SET AN/GRC-106)

J3 TO HANDSET  
(SUCH AS HANDSET H-33PT)

J4 TO LOCAL OR REMOTE LOUDSPEAKER  
(SUCH AS DYNAMIC LOUDSPEAKER LS-166/U)

J5 TO LOCAL/REMOTE CONTROL  
(SUCH AS CONTROL RADIO SET C-4846/GRA-74)

J6 and J7 TO TTY MACHINE  
(SUCH AS TELETYPEWRITER TT-98/FG)

J8 TO NOMINAL 27V DC POWER SOURCE

FIGURE 2-2. CONNECTING MODEM TO TYPICAL EQUIPMENT (1 OF 2)

REF DESIG	PIN	CONNECTION
J1	A	FROM AUX RECEIVER AUDIO
	B	GROUND
	C	SPARE
	D	SPARE
	E	GROUND
	F	SPARE
	G	SPARE
	H	GROUND
	J	SPARE
	K	SPARE
	J2	A
B		GROUND
c		TO RECEIVER-TRANSMITTER 50 OHM MICROPHONE INPUT
D		COMMON FOR PINS C AND J
E		GROUND
F		RECEIVER-TRANSMITTER KEYLINE
G		SPARE
H		GROUND
J		TO RECEIVER-TRANSMITTER 600 OHM INPUT
K		COMMON BUSS TO PIN K ON J3 AND J4
J3		A
	B	GROUND
	c	50 OHM MICROPHONE INPUT
	D	SPARE
	E	MICROPHONE RETURN
	F	RECEIVER-TRANSMITTER KEYLINE
	H	GROUND
	J	600 OHM AUDIO INPUT
	K	COMMON BUSS TO PIN K ON J2 AND J4
	L	SPARE

REF DESIG	PIN	CONNECTION
J4	A	10 MW OUTPUT TO HEADPHONES
	B	GROUND
	c	50 OHM MICROPHONE INPUT
	D	SPARE
	E	GROUND
	F	RECEIVER-TRANSMITTER KEYLINE
	H	GROUND
	J	600 OHM AUDIO INPUT
	K	COMMON BUSS TO PIN K ON
	L	2-WATT OUTPUT TO SPEAKER
	J5	A
B		GROUND
c		AUX PRIMARY POWER SOURCE (NOMINAL +27 VDC UNFUSED)
D		RECEIVER-TRANSMITTER KEYLINE
E		REMOTE SEND-RCV SWITCH
F		SPARE
G		SPARE
H		SPARE
J		SPARE
K		SPARE
J6		A
	B	GROUND
	c	DC LOOP NO. 1 NEGATIVE SIDE (INTERNAL SUPPLY)
J7	A	DC LOOP NO. 2 POSITIVE SIDE (INTERNAL SUPPLY)
	B	GROUND
	c	DC LOOP NO. 2 NEGATIVE SIDE (INTERNAL SUPPLY)
J8	A	+27 VDC NOMINAL
	B	+27 VDC NOMINAL
	c	GROUND
	D	GROUND

FIGURE 2-2. CONNECTING MODEM TYPICAL EQUIPMENT (2 OF 2)

**d. Preliminary Servicing and Adjustment of Equipment**

Make initial adjustments after installing modem but before beginning routine operation,

**NOTE**

The following adjustments can only be made with modem chassis removed from its case (para 2-9).

**e. Adjusting Loop Current Internal/External Switch**

- Current for dc loop No. 1 and dc loop No. 2 may be supplied by internal loop battery module A5 (see figure) or by external means.

CHASSIS INTERIOR, TOP VIEW

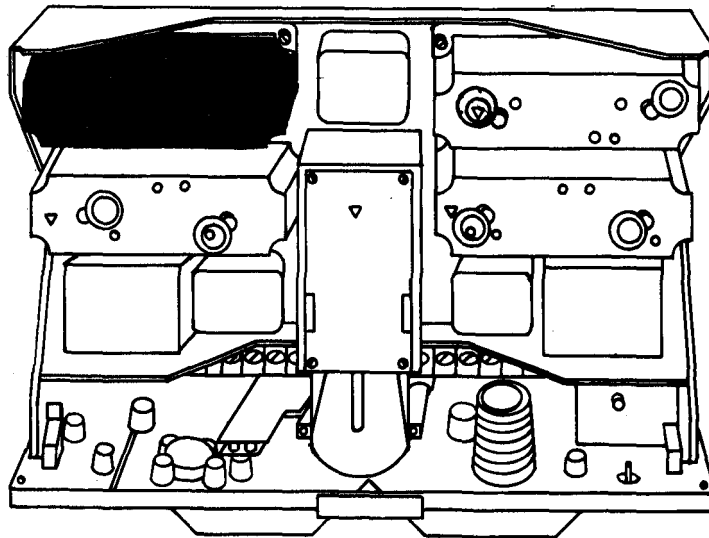

- Internal/External switch A5S1 is a screwdriver adjustment on top of module A5 which sets the appropriate sources of current for dc loops No. 1 and No. 2. See figure for settings provided.

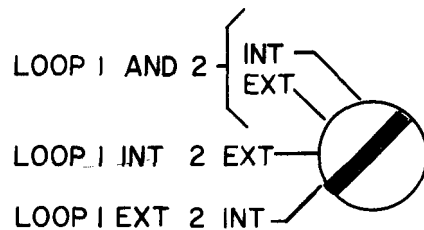

- A5S1 is normally set at LOOP 1 AND 2 INT when modem is shipped from the factory.
- Set A5S1 according to desired sources of loop current for dc loops No. 1 and 2.

**f. Adjusting Transmit Norm/Rev Switch**

- In most teletypewriter transmission and reception, lower frequency tone is used for mark pulses and higher frequency tone for space pulses.

Transmit NORM/REV toggle switch A3A1S1 located on board A3A1 of transmitter module A3 (see figure) permits modem to transmit mark-space tones in reverse, if necessary.

**SWITCH A3A1S1 (INSIDE)  
CHASSIS INTERIOR,  
TOP VIEW**

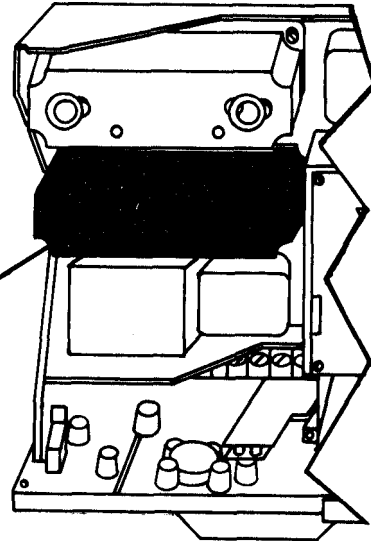

- Remove module dustcover as described in paragraph 2-9b.
- Set NORM/REV switch according to type of transmission required.
- Replace module dustcover.

**Section III. PREVENTIVE MAINTENANCE CHECKS AND SERVICES (PMCS)**

**2-5. GENERAL**

The following information is for QUARTERLY preventive maintenance checks and services (PMCS) of modem. Quarterly PMCS should be performed every 90 calendar days of 8-hour-per-day operation. Maintenance forms and records to be used and maintained on this equipment are specified in DA PAM 738-750. Perform all checks and services in sequence listed in table 2-1. If the equipment is operated 16 hours, check at 45 day intervals.

**NOTE**

PMCS for the modem is limited to exterior and interior of chassis and case and to exterior of modules ONLY.

**a. Tools, Test Equipment and Material Needed for Organizational Level Maintenance**

- All tools you will need for maintenance on the modem are in Tool Kit, Electronic Equipment TK 101/G (SC 5180-91-CL-R13).
- Required test equipment: Multi meter AN/URM-105 (TM 11-6625-203-12).
- Required material:
 

Cement, 3M Co. ED-847	(item No. 1, app. C)
Cleaning compound	(item No. 2, app. C)
Cleaning cloth	(item No. 3, app. C)
Fine sandpaper	(item No. 4, app. C)
Soft-bristle brush	(item No. 5, app. C)
Dishwashing detergent	(item No. 6, app. C)

## b. Routine Services

Routine services are a collection of checks and observations performed by the organizational maintenance at all times, Routine services are not listed in the preventive maintenance checks and services table, in order to separate the nonoperational from the operational services.

You should perform the following routines as necessary. Organizational maintenance personnel will not be required to perform routine operator services or functions.

- Check for cut or frayed cables
- Check for rusting
- Check for dented, bent, or broken components
- Check for loose nuts, bolts, and connectors

Service the following items:

- Chassis
- Modules
- Jacks
- Gaskets

If you find any damage during PMCS, refer to the troubleshooting table (table 2-2) or the maintenance procedures in this manual for instructions on how to correct it. If the instructions are not there, notify your supervisor. A higher category of maintenance may be required.

### NOTE

Use the number from the ITEM column of the PMCS table as the TM ITEM No. for DA Form 2404 (Equipment Inspection and Maintenance Worksheet). (See page 2-9).

DA FORM 2404, EQUIPMENT INSPECTION AND MAINTENANCE WORKSHEET.

EQUIPMENT INSPECTION AND MAINTENANCE WORKSHEET										
For use of this form see TM 38-750, the proponent agency is the Office of the Deputy Chief of Staff for Logistics										
1. ORGANIZATION <b>COMPANY A 210 SIG BATTALION</b>					2. NOMENCLATURE AND MODEL <b>Radio Teletypewriter Modem, HD-522A/GZC</b>					
3. REGISTRATION/SERIAL/FSN <b>1436</b>		4a. MILES	b. HOURS	c. ROUNDS FIRED	d. HOT STARTS	5. DATE <b>16. DEC 1980</b>		6. TYPE INSPECTION <b>PMCS</b>		
7. APPLICABLE REFERENCE										
TM NUMBER <b>11-5805-387-20-2</b>			TM DATE <b>15 DEC 1980</b>		TM NUMBER			TM DATE		
INSTRUCTIONS - Perform each check listed in the TM applicable to the inspection performed, Following the sequence listed in pertinent TM, complete form as follows:										
COLUMN a - Enter TM item number.					COLUMN d - Show corrective action for deficiency or shortcoming listed in Column c.					
COLUMN b - Enter the applicable condition status symbol.					COLUMN e - Individual ascertaining completed corrective action initial in this column.					
COLUMN c - Enter deficiencies and shortcomings.										
ALL INSPECTIONS AND EQUIPMENT CONDITIONS RECORDED ON THIS FORM HAVE BEEN DETERMINED IN ACCORDANCE WITH DIAGNOSTIC PROCEDURES AND STANDARDS IN THE TM CITED HEREON.										
8a. SIGNATURE (Person(s) performing inspection)			8b. TIME		9a. SIGNATURE (Maintenance Supervisor)			9b. TIME		10. MANHOURS REQUIRED
<i>[Signature]</i>			0.5 hr		<i>Sgt. James Johnson</i>			0.2 hr		0.7 hr
TM ITEM NO.	STATUS	DEFICIENCIES AND SHORTCOMINGS			CORRECTIVE ACTION			INITIAL WHEN CORRECTED		
3		front panel gasket cracked			replaced gasket			JD		

TABLE 2-1. QUARTERLY PMCS TABLE

ITEM NO.	ITEM TO BE INSPECTED	PROCEDURES
1	Operational Check	Check the modem by operating it. (Refer to TM 11-5805-387-10-2.)
2	Front Panel Meter	<p>Be sure meter is showing correct indication for dc power input, discriminator, dc loops or RCV setting, depending on operation.</p> 
3	Voice Signal	<p>Perform the following check (Refer to voice transmission procedure in TM 11-5805-387-10-2)</p> <ol style="list-style-type: none"> <li>Put on headset.</li> <li>Attach microphone at microphone connector.</li> <li>Press and hold switch to key microphone and talk.</li> <li>Note sidetone in headset.</li> </ol> 



TABLE 2-1. QUARTERLY PMCS TABLE - Continued

ITEM NO.	ITEM TO BE INSPECTED	PROCEDURES
4	Front Panel Gasket	Inspect front panel gasket for leaks, cracks, and worn or loose edges. Replace if necessary. (See paragraph 2-11).
5	Scope	<p>Inspect scope to see if it is working properly.</p> 
6	Modules	<p>Be sure that module plugs and sockets are clean, intact, and firmly seated. Firmly seat all five modules if necessary.</p>  <p>MD-522A/GRC: CHASSIS INTERIOR, TOP VIEW</p>

TABLE 2-1. QUARTERLY PMCS TABLE - Continued

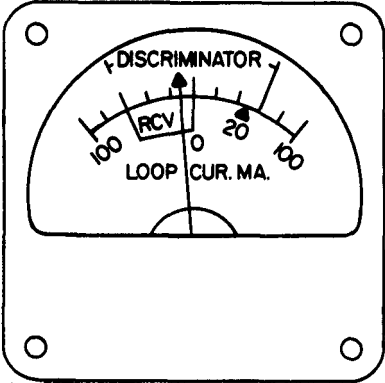
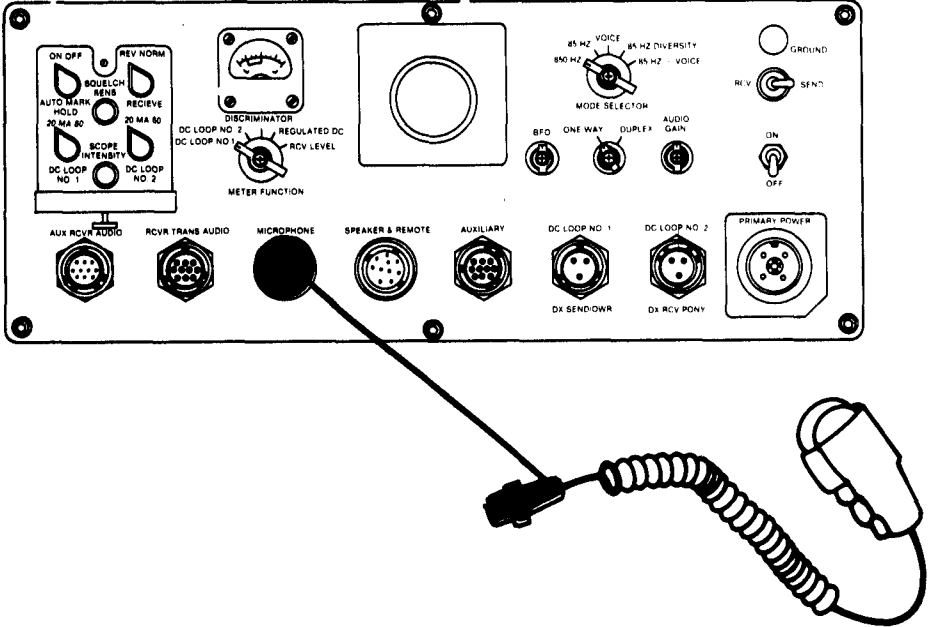
ITEM NO.	ITEM TO BE INSPECTED	PROCEDURES
7	Publications	Check DA PAM 310-1 to determine if new applicable MWO's have been applied. All URGENT MWO's must be applied immediately.

## Section IV. TROUBLESHOOTING

### 2-6. GENERAL

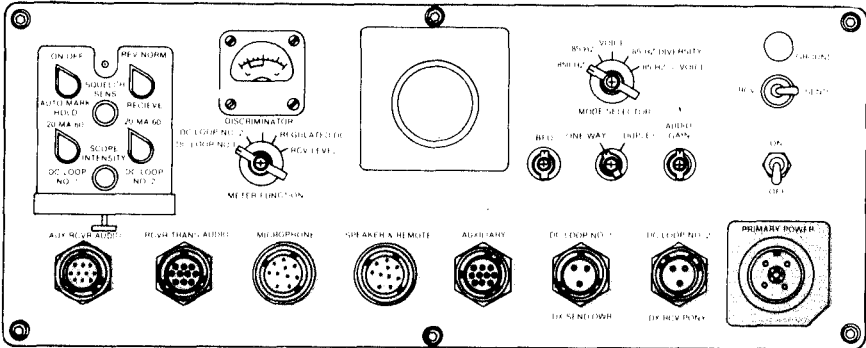
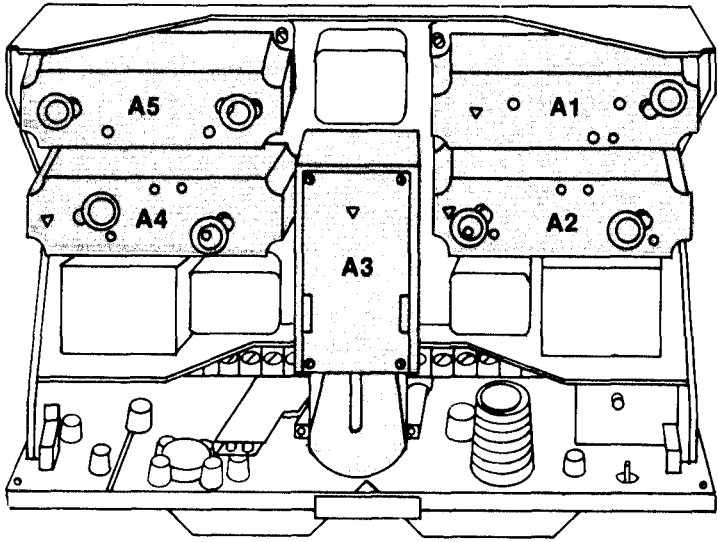
- Ž Troubleshooting at the organizational maintenance level requires you to locate any trouble as quickly as possible.
- Once trouble is located, repair or replace the part if you are authorized to do so or determine if a higher category of maintenance is required. Repairs by organizational maintenance are limited by tools, test equipment and replacement parts allocated to that level.

#### NOTE

Before using troubleshooting table (table 2-2), check your work order and talk to the operator, if possible, for a description of symptoms if trouble occurred while equipment was in operation.

#### Troubleshooting Table (Table 2-2)

- Table 2-2 lists common problems that may occur during operation or maintenance of the modem.
- Ž Follow these steps to use table 2-2:
  - Ž Find the problem under MALFUNCTION.
  - Ž Check for possible causes of the problem under TEST OR INSPECTION.
  - Use the procedures under CORRECTIVE ACTION to correct the problem.
- This manual cannot list all trouble that may occur, nor everything to check nor all possible procedures to correct troubles listed. If trouble is not listed in table 2-2 or is not corrected by the procedures under CORRECTIVE ACTION, notify your supervisor.

#### WARNING

Dangerous voltages exist in this equipment. For some of the following procedures, you must remove the modem chassis from its case. Set ON/OFF F circuit breaker switch on front of panel to OFF before removing chassis, then follow instructions in paragraph 2-9 for removal.

Table 2-2 TROUBLESHOOTING

**MALFUNCTION**

**TEST OR INSPECTION**

**CORRECTIVE ACTION**

**1. No +20 volt dc indication on front panel meter**

Step 1. See if circuit breaker is tripped.

**CAUTION**

To prevent damage to the equipment, do not hold ON/OFF circuit breaker switch on front panel in ON position.

- Reset circuit breaker switch to ON.
- If it trips again, higher category maintenance required.

Step 2. Use Multimeter AN/URM-105 to check for 28 volts dc between pins A (+) and C (-) of POWER input cable.

- Turn circuit breaker ON/OFF switch to OFF.
- Disconnect POWER cable from primary power connector.
- Connect multimeter as shown in figure.

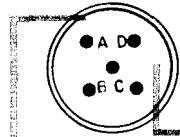

**POWER  
CABLE**

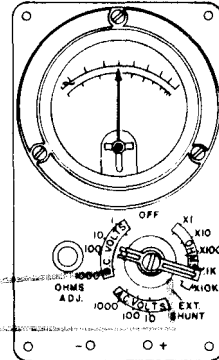

**MULTIMETER  
AN/URM-105**

- If 28 volts dc is absent, replace POWER cable.
- If 28 volts dc is present, go to 2.

**2. No +20 volt dc indication on front panel meter but primary power input normal**

Step 1. Be sure modules are securely seated in their sockets.

**CHASSIS INTERIOR, TOP VIEW**

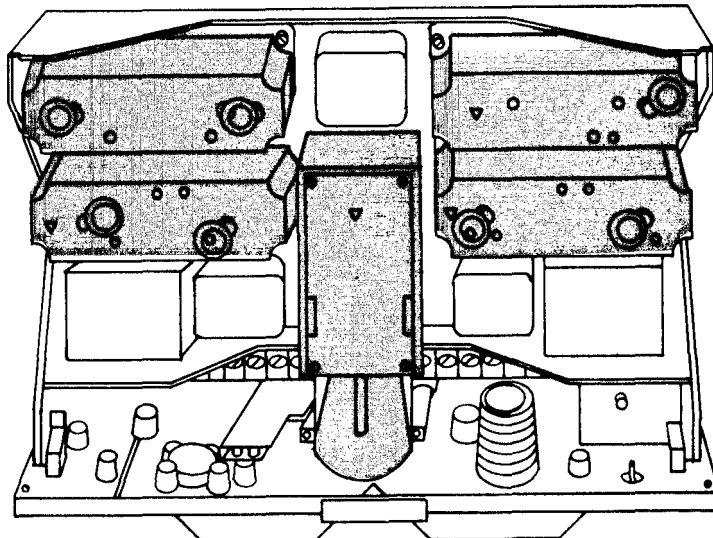

Securely seat all modules in their sockets.

Table 2-2 TROUBLESHOOTING - Continued

**MALFUNCTION**

**TEST OR INSPECTION**

**CORRECTIVE ACTION**

Step 2. Use Multimeter AN/URM-105 to check switches S3 and S4 for bad contacts.

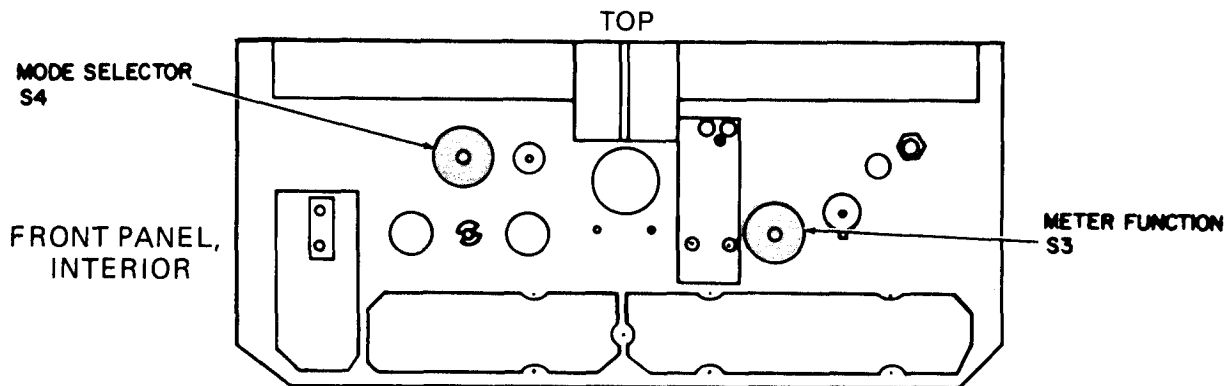

- If contacts are bad or there is not +20 volt dc indication on meter after reconnecting POWER cable, higher category of maintenance required.

**3. No indication on front panel meter with METER FUNCTION switch at RCV LEVEL**

Step 1. Check for loose or damaged RCVR TRANS AUDIO or AUX RCVR AUDIO cables.

- Be sure the associated receiver is working properly and the appropriate connectors are clean and fit tightly.

Step 2. Use Multimeter AN/URM-105 to check switches S3 and S1 for bad contacts.

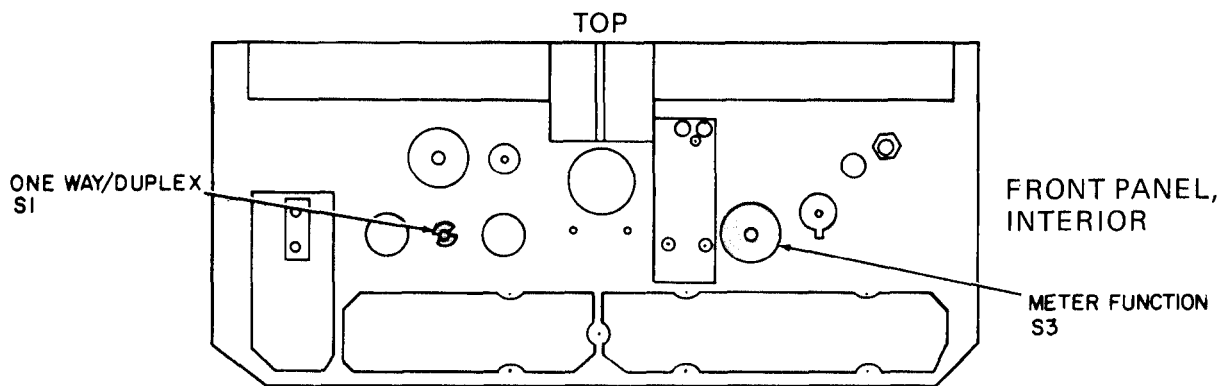

- If contacts are bad, higher category of maintenance required.

Table 2-2 TROUBLESHOOTING - Continued

**MALFUNCTION**

**TEST OR INSPECTION**

**CORRECTIVE ACTION**

Step 3. Be sure receiver audio module A1 is securely seated in a corrosion-free socket.

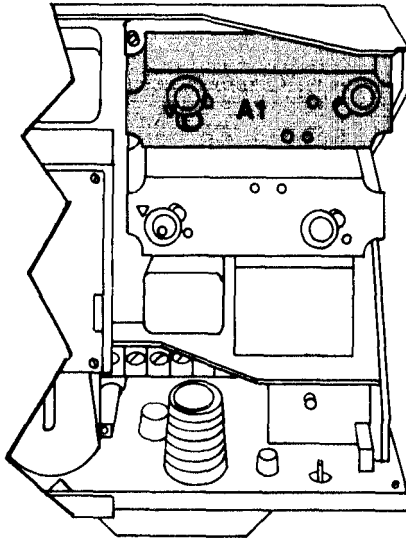

CHASSIS INTERIOR, TOP VIEW

Remove module A1 from its socket and visually check for any rust or corrosion. Remove corrosion by lightly sanding with fine sandpaper. Securely seat module A1 back in its socket.

**4. Incorrect meter function with METER FUNCTION switch at DISCRIMINATOR**

Be sure receiver module A4 is securely seated in a corrosion-free socket.

CHASSIS INTERIOR, TOP VIEW

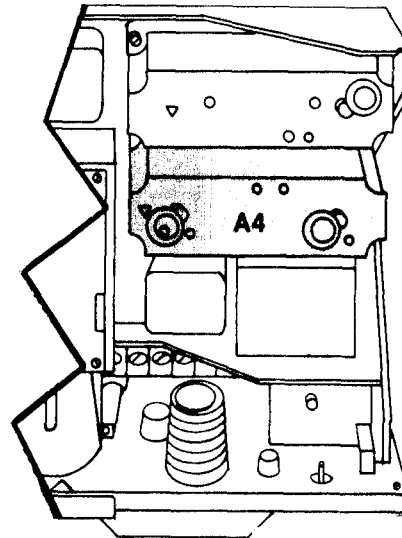

Remove module A4 from its socket and visually check for any rust or corrosion. Remove corrosion by lightly sanding with fine sandpaper. Securely seat module A4 back in its socket.

Table 2-2 TROUBLESHOOTING - Continued

**MALFUNCTION**

**TEST OR INSPECTION**

**CORRECTIVE ACTION**

**5. No indication on front panel meter of loop current in dc loops No. 1 and No. 2.**

Step 1. Check for loose or damaged dc loop No. 1 or dc loop No. 2 cables.

- Be sure that the appropriate connector is clean and fits tightly. If cables are shorted or have open conductors, replace them.

Step 2. Use Multimeter AN/URM-105 to check switch S3 for bad contacts. (See malfunction 2 for location of switch S3.)

- If contacts are bad, higher category of maintenance required.

Step 3. Be sure loop battery module A5 is securely seated in a corrosion-free socket.

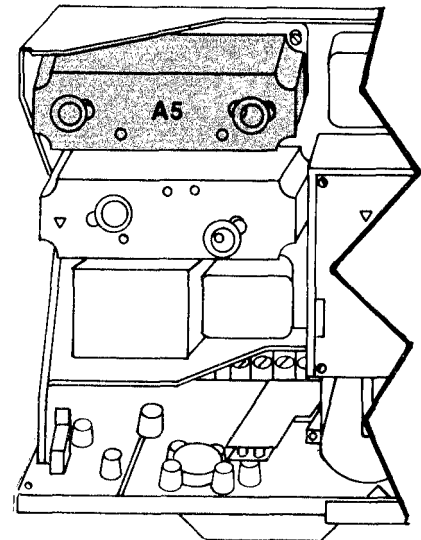

CHASSIS INTERIOR, TOP VIEW

Step 4. Use Multimeter AN/UM-105 to check switch S2 for bad contacts.

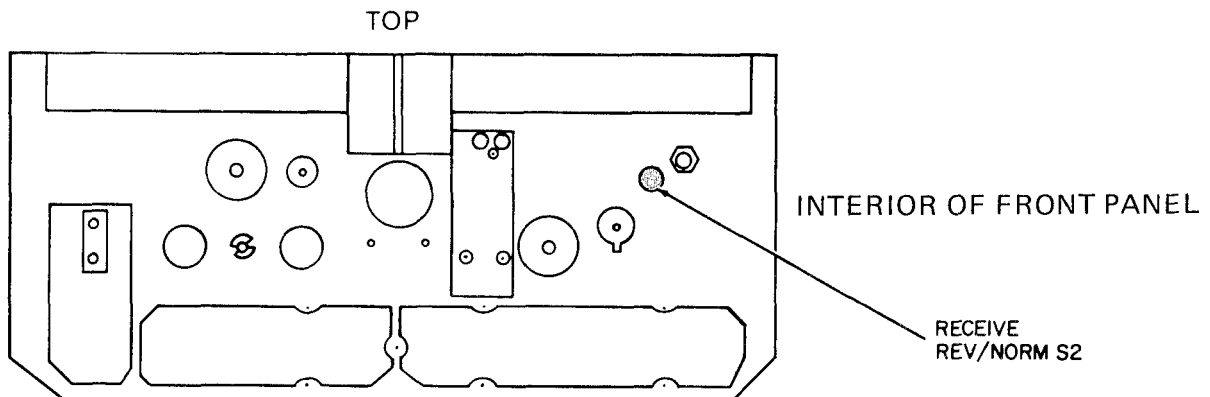

- If contacts are bad, higher category of maintenance required.

Table 2-2 TROUBLESHOOTING – Continued

**MALFUNCTION**

**TEST OR INSPECTION**

**CORRECTIVE ACTION**

6. Scope display malfunction. (See figures for scope traces for properly tuned associated radio receivers).

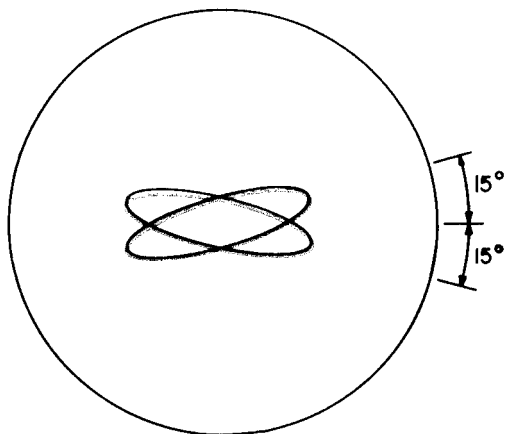

**NSK TUNED  
CORRECTLY**

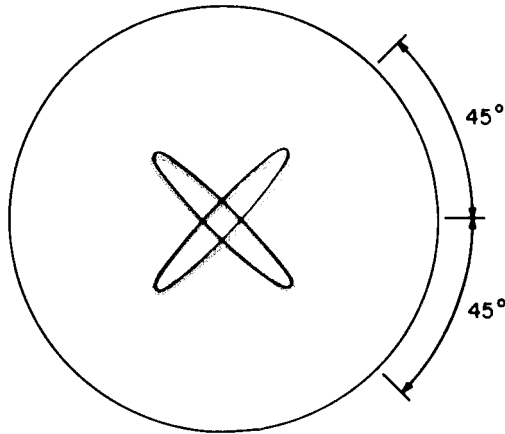

**FSK TUNED  
CORRECTLY**

Be sure scope module A2 is securely seated in a corrosion-free socket.

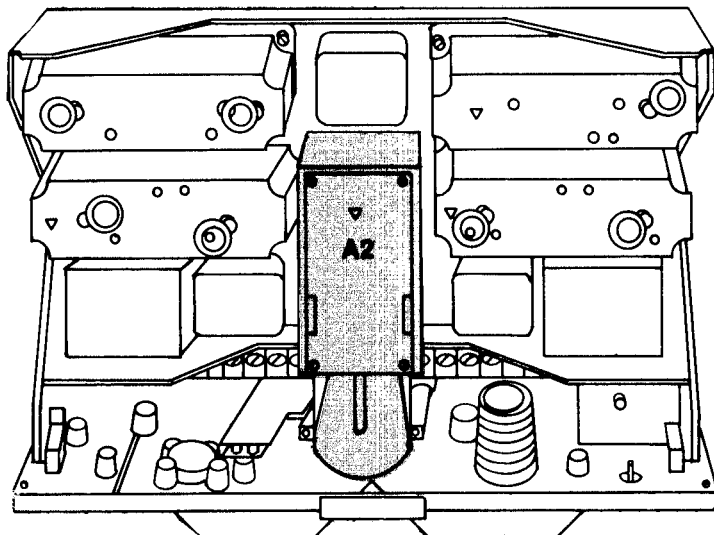

**CHASSIS INTERIOR, TOP VIEW**

Remove module A2 (para 2-9c) from its socket and visually check for any rust or corrosion. Remove corrosion by lightly sanding with fine sandpaper. Securely seat module A2 back in its socket.



Table 2-2 TROUBLESHOOTING - Continued

**MALFUNCTION**

**TEST OR INSPECTION**

**CORRECTIVE ACTION**

**7. No voice reception**

Step 1. Be sure receiver module A4 is securely seated in a corrosion-free socket.

See malfunction 4.

Step 2. Check for loose or damaged SPEAKER + REMOTE or MICROPHONE cables.

Be sure that associated connectors are clean and fit tightly. If cables are shorted or have open conductors, replace them.

Step 3. Use Multimeter AN/URM-105 to check switch S4E for bad contacts. (See malfunction 2 for location of S4.)

If contacts are bad, higher category of maintenance required.

**8. No voice transmission; teletypewriter (tty) normal**

Step 1. Check for loose or damaged AUXILIARY, SPEAKER + REMOTE or MICROPHONE cables.

Be sure that associated connectors are clean and fit tightly. If cables are shorted or have open conductors, replace them.

Step 2. Use Multimeter AN/URM-105 to check switch S4B or S4C for bad contacts. (See malfunction 2 for location of S4.)

If contacts are bad, higher category of maintenance required.

**9. No tty transmission; voice normal**

Use Multimeter AN/URM-105 to check switch S4D for bad contacts. (See malfunction 2 for location of S4.)

If contacts are bad, higher category of maintenance required.

**10. No tty or voice transmission**

Be sure transistor module A3 is securely seated in a corrosion-free socket.

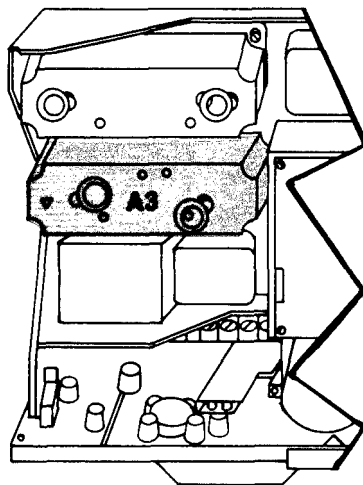

**CHASSIS INTERIOR, TOP VIEW**

Remove module A3 from its socket and visually check for any rust or corrosion. Remove corrosion by lightly sanding with fine sandpaper. Securely seat module A3 back in its socket.

## Section V. MAINTENANCE PROCEDURES

### 2-7. GENERAL

Organizational maintenance of the modem is limited to:

#### 1. INSPECTION

- Interior of modem and exterior of modules.

#### 2. REMOVAL

- Modem chassis from case.
- Module dust covers.
- Modules.

#### 3. CLEANING

- Exterior and interior of modem case and chassis and exterior of modules,

#### 4. REPAIRS AND REPLACEMENTS

- Front panel gasket.
- Module dust covers.
- Modules.
- Modem chassis into case.

#### 5. TESTING

- Front panel assembly.

#### 6. PAINTING

- Metal surfaces.

#### 7. ADJUSTMENTS

- All controls on exterior of modem.

### 2-8. INSPECTION AND SERVICE

Inspect and service interior of modem case and exterior of modules. Do not remove module covers. Check for dirt, dust, or moisture; check for loose screws or nuts. Check for loose or broken control knobs and shorted or open connector contacts.

### 2-9. REMOVAL

#### a. Modem Chassis from Case

Follow procedure given below:

#### **WARNING**

To prevent dangerous shocks, set ON/OFF circuit breaker switch on front panel of modem to OFF before removing chassis.

- Disconnect and label all external cables from front panel connectors.

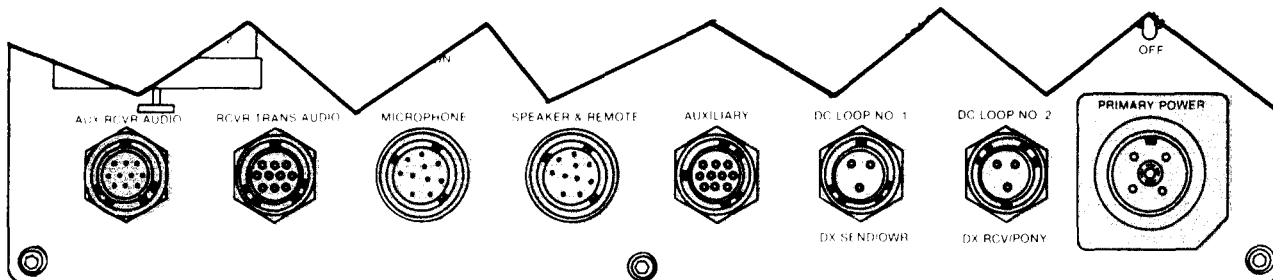

- Loosen six captive screws around outside edge of front panel.

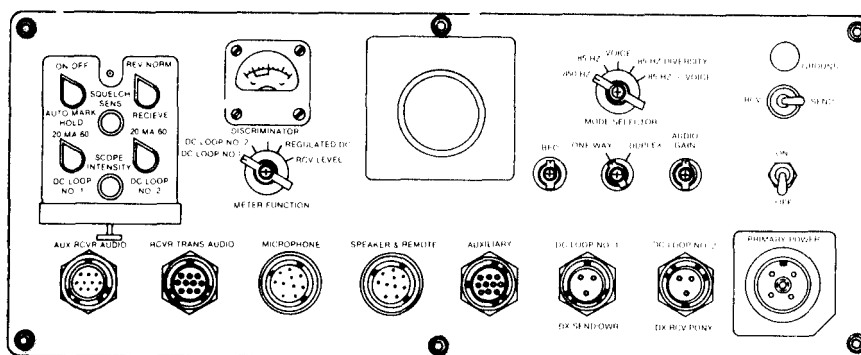

**WARNING**

Be careful when pulling modem chassis from case; it weighs 36 pounds.

- Grasp raised ribbed frame around outside edge of front panel. Gently pull modem chassis out of case.

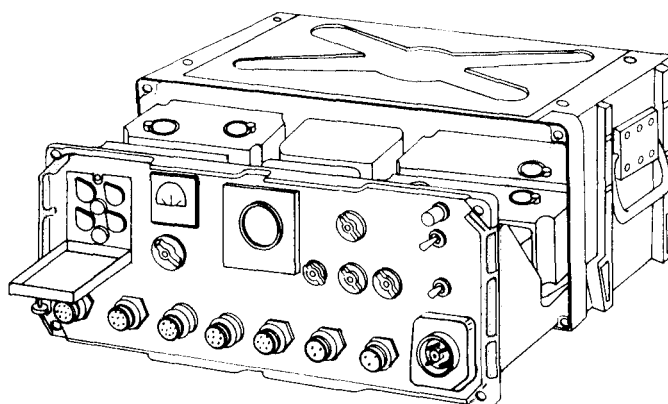

**b. Module Dust Cover**

- Lift up bail handles and turn them to the left until they release. Lift off cover.
- For scope module A2, remove four screws from cover and lift it off.

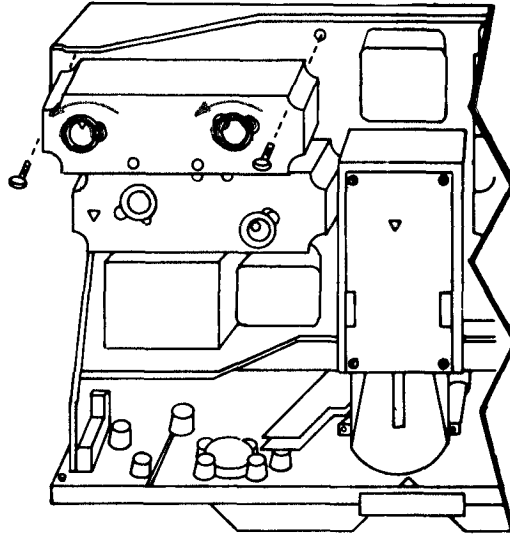

**c. Modules**

- Remove screw, lockwasher, washer and spring from each corner of module.
- Pull up on module (or bail handle if cover has not been removed) to unplug module from chassis connector.

**2-10. CLEANING**

Clean exterior and interior of modem chassis and case and exterior of modules only. Do not remove module covers.

**CAUTION**

Do not press on meter or scope face when cleaning.

- Remove dust and loose dirt from outside surfaces of the modem with a clean, soft cloth (item 3, app. C). Cloth may be dampened with water, and mild soap (item 6, app. C) may be used for better cleaning.

**WARNING**

See trichlorotrifluoroethane warning on page a.

**WARNING**

See compressed air warning on page a.

- Remove grease, fungus and ground-in dirt from case. Use a cloth dampened (not wet) with cleaning compound (item 2, app. C).
- Remove dust or dirt from plugs and jacks with a brush (item 5, app. C).

## 2-11. REMOVAL AND REPLACEMENTS

### a. Front Panel Gasket

Replace front panel gasket on modem if it is cracked, broken, frayed, worn, or out of its groove and flattened. Follow this procedure:

- Follow instructions given in paragraph 2-9 for removing modem from case. Pull chassis out only far enough to loosen front panel gasket.
- **Remove old gasket.**

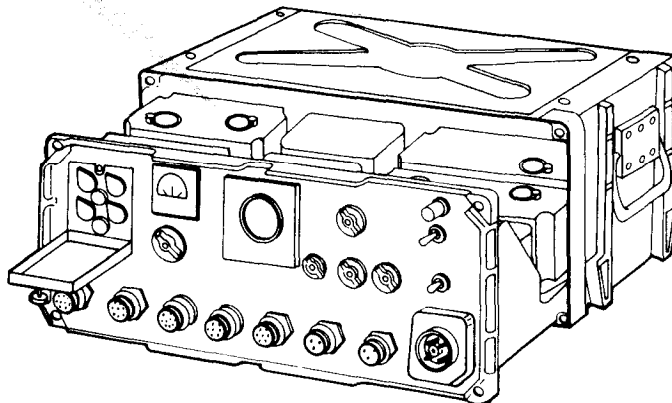

### **WARNING**

See trichlorotrifluoroethane warning on page a.

### **WARNING**

See compressed air warning on page a.

- Remove all cement and dirt from groove in which gasket is seated. Use a cloth dampened (not wet) with cleaning compound (item 2, app. C).
- Spread thin film of EC-847 cement (item 1, app. C) in groove.
- Place new gasket in groove. Gently press to insure complete bonding.

### **NOTE**

Let cement dry for at least 1 hour before placing chassis back into case, so the gasket won't stick to the chassis.

- Follow instructions in paragraph below to replace chassis into case after replacing front panel gasket.

### b. Module Dust Covers

- Place dust cover over module. Turn bail handles to the right until they are tight.
- For scope module A2, place cover over module and tighten four screws to hold cover in place.

### c. Modules

- Plug module into appropriate chassis connector.
- Secure modules to chassis by tightening screws with springs, lock washers and washers in each corner of module.

**d. Replacing Modem Chassis into Case**

Follow procedure given below:

- Be sure modem case is top side up. (Four depressions on top of case.)
- Grasp chassis by raised ribbed frame (not components); begin sliding chassis into case. When about 1 inch of chassis remains outside case, maneuver chassis until it engages guide prongs at back of case. Slide chassis into case.

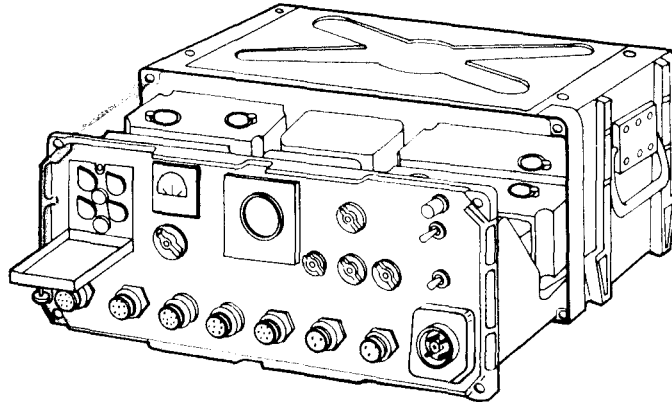

- Alternately tighten six captive holddown screws around outside edge of front panel.

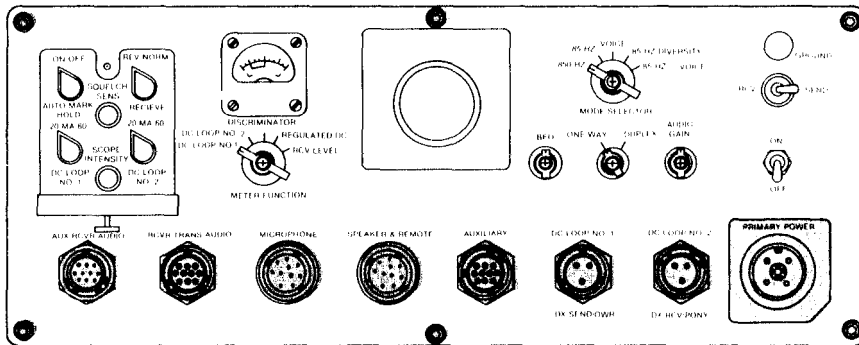

- Reconnect any cables that may have been removed. Remove temporary cable labels. Be sure all cables fit tightly in their correct sockets.
- Tighten six screws.

**2-12. TESTING**

Locate faulty components mounted on front panel and check for shorts at the power connector.

**2-13. PAINTING**

Remove rust and corrosion from metal surfaces by lightly sanding with fine sandpaper (item 4, app. C). Brush two thin coats of the proper paint on bare metal to protect it from further corrosion. Refer to applicable procedures in TB 43-0118.

**2-14. ADJUSTMENT**

Check front panel controls to be sure that they operate freely.

**Section VI. PREPARATION FOR STORAGE OR SHIPMENT**

**2-15. SECURITY PROCEDURES**

Refer to AR 190-11 or AR 190-13.

**2-16. DISASSEMBLY OF EQUIPMENT**

Use the procedures below when placing the modem in storage or moving it to a different location.

**a. Disconnecting Cables**

- Set modem circuit breaker switch to OFF.

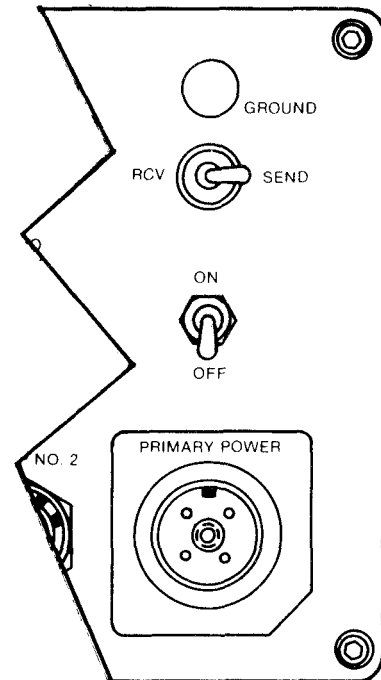

- Disconnect power cable from PRIMARY POWER connector.

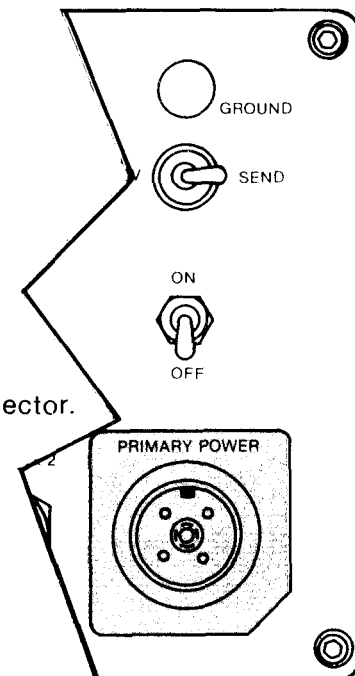

- Disconnect all cables attached to front panel connectors. Replace dust caps on connectors.

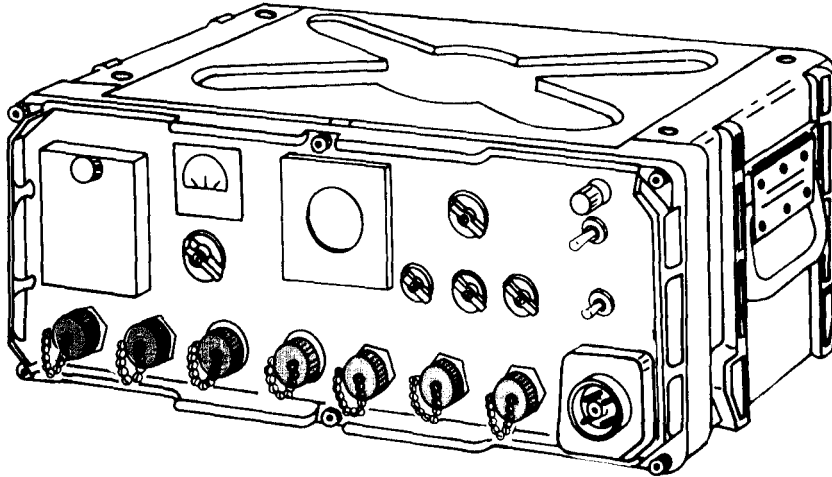

- Close hinged cover at upper left front panel. Secure it by turning the thumbscrew to the right.

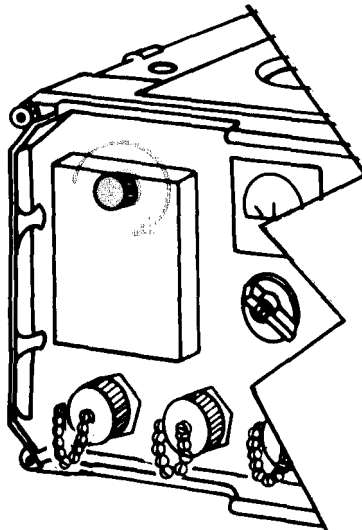

**b. Component Disassembly**

- If the modem is installed on a mounting base, such as MT-3140/GRC-106, pull release handles on the base towards you while turning them towards the outside of the unit.
- Lift the modem off of the mounting base.

**2-17. REPACKING FOR SHIPMENT**

- If the modem is to be moved over a short distance for immediate reuse, put it in a corrugated or wooden box and place padding over the control panel. Use rags or crumpled paper for padding.



**NOTE**

Do not stack other equipment on top of modem.

**2-18. REPACKING FOR STORAGE**

If modem is to be stored for longer than two weeks or is to be shipped for use by other personnel or activities, return it to its original shipping container (fig. 2-1).

- Fold a piece of corrugated cardboard (W5c, B-flute) to form a spring (shock) pad for bottom of carton. Set the spring pad in the carton.
- Place the modem in the carton.
- Fold sheets of corrugated cardboard to form spring pads for the front, rear and sides of the modem; set them in place.
- Slide a sheet of corrugated (A/B) doublewall cardboard between the front spring pad and the carton wall.
- Fold a sheet of corrugated cardboard to form a spring pad for the top of the modem. Set it in place.
- Close the carton cover and secure the edges with water resistant tape (PPP-T-76, 3-inch).
- Place all TM's in a barrier bag and tape the bag closed.

**2-19. TYPES OF STORAGE**

- Short term (administrative) = 1 to 45 days. All equipment in administrative storage must be able to be made ready within 24 hours for use on a mission. Before placing any item in administrative storage, perform the next scheduled PMCS and correct or repair any deficiencies you find. The administrative storage site should provide required protection from extreme weather conditions and allow you to reach the equipment for visual inspections or exercises when applicable.
- Intermediate = 46 to 180 days.
- Long term or flyable = no time limit.



**APPENDIX A**

**REFERENCES**

**A-1. INTRODUCTION**

The Consolidated Index of Army Publications and Blank Forms, DA PAM 310-1, should be consulted frequently for revisions and new publications that pertain to this manual. The following is a list of all forms, technical bulletins and technical manuals referenced in this manual.

**A-2. FORMS**

DA Form 2028 . . . . .	Recommended Changes to Publications and Blank Forms
DA Form 2404 . . . . .	Equipment Inspection and Maintenance Worksheet
SF Form 361. . . . .	Discrepancy in Shipment Report
SF Form 364 . . . . .	Report of Discrepancy (ROD)
SF Form 368 . . . . .	Quality Deficiency Report

**A-3. TECHNICAL BULLETINS**

TB43-0116. . . . .	Identifications of Radioactive Items in the Army Supply System
TB43-0118 . . . . .	Field Instructions for Painting and Preserving Electronics Command Equipment Including Camouflage Pattern Painting of Electronic Shelter
TB43-0122 . . . . .	Instructions for the Safe Handling and Identification of US Army Communication-Electronics Command Managed Radioactive Items in the US Army Supply System

**A-4. TECHNICAL MANUALS**

TM11-5805-387-10-1 . . . . .	Operator's Manual: Modem Radio Teletypewriter MD-522/GR
TM 11-5805-387-20P-2. . . . .	Organizational Repair Parts List: Modem Radio Teletypewriter MD-522/GRC
TM 11-5805-387-24P-1 . . . . .	Organizational, Direct Support, and General Support Maintenance Repair Parts and Special Tools Lists (Including Depot Maintenance Repair Parts and Special Tools) for Modem Radio Teletypewriter MD-522/GRC (NSN 581 5-00-919-4800)
TM 11-5805-387-34-2 . . . . .	Direct Support and General Support Maintenance: Modem Radio Teletypewriter MD-522A/GRC
TM 11-6625-203-12 . . . . .	Operator's and Organizational Maintenance Manual: Multi-meter AN/URM-105 Including Multimeter ME-77/U

**TM 11-5806-387-20-1**

- TM740-90-1 . . . . . Administrative Storage of Equipment
- TM750-244-2 . . . . . Procedures for Destruction of Electronic Materiel to Prevent  
Enemy Use (Electronics Command)

**A-5. MISCELLANEOUS PUBLICATIONS**

- AR 190-11 . . . . . Physical Security of Arms, Ammunition, and Explosives
- AR 190-13 . . . . . The Army Physical Security Program
- AR 385-11 . . . . . Ionizing Radiation Protection (Licensing, Control, Transportation, Disposal, and Radiation Safety)
- DA PAM310-1 . . . . . Consolidated Index of Army Publications and Blank Forms
- DA PAM 738-750 . . . . . The Army Maintenance Management System (TAMMS)
- SC-5180-91-CL-R . . . . . Sets, Kits and Outfits, Component List: Tool  
Kit, Electronics Equipment, TK101/G

## APPENDIX B MAINTENANCE ALLOCATION

### Section I. INTRODUCTION

#### B-1. GENERAL

This appendix provides a summary of maintenance operations for MD-522A/GRC. It authorizes categories of maintenance for specific maintenance functions on repairable items and components, as well as tools and equipment needed to perform each function. Use this appendix as an aid in planning maintenance operations.

#### B-2. MAINTENANCE FUNCTION

Maintenance functions will be limited to and defined as follows:

- a. **INSPECT.** To visually examine an item and compare its physical, mechanical and/or electrical characteristics with established standards in order to determine its serviceability.
- b. **TEST.** To measure mechanical or electrical characteristics of an item and compare those characteristics with prescribed standards in order to verify serviceability.
- c. **SERVICE.** Procedures required periodically to keep an item in proper operating condition, e.g., to clean (decontaminate), preserve, drain, paint, or to fill up fuel, lubrication, hydraulic fluid, or compressed air supplies.
- d. **ADJUST.** To set operating characteristics to the specified parameters and keep them within their prescribed limits.
- e. **ALIGN.** To adjust specified variable elements of an item to bring about the best or desired performance.
- f. **CALIBRATE.** To correct test measuring and diagnostic equipment used in precision measurements. Must compare two instruments, one of which is a certified standard of known accuracy, to detect and adjust any differences in the accuracy of the instrument being compared.
- g. **INSTALL.** To place, seat or fix into position an item, part or module (component or assembly) to allow proper functioning of equipment or system.
- h. **REPLACE.** To substitute a functioning like type part, subassembly or module (component or assembly) for its unserviceable counterpart.
- i. **REPAIR.** To correct specific damage, fault, malfunction or failure in a part, subassembly, module (component or assembly), end item or system by applying maintenance services (a-f, h above) or other maintenance actions (welding, grinding, riveting, straightening, facing, remachining or resurfacing). This function does not include trial and error replacement of such items as fuses, lamps or electron tubes.
- j. **OVERHAUL.** The highest degree of maintenance applied to Army equipment. This function does not normally return an item to "like new" condition but restores it to completely serviceable/operational conditions according to maintenance standards (i.e., DMWR) in appropriate technical publications.
- k. **REBUILD.** The highest degree of materiel maintenance applied to Army equipment. To restore unserviceable equipment to a "like new" condition according to original manufacturing standards. This function includes returning to zero those age measurements (hours, miles, etc.) considered in classifying Army equipment/components.

**B-3. COLUMN ENTRIES**

- a. **COLUMN 1: GROUP NUMBER.** Identifies components, assemblies, subassemblies and modules with next higher assembly.
- b. **COLUMN 2: COMPONENT/ASSEMBLY.** Lists the noun names of components, assemblies, subassemblies and modules for which maintenance is authorized.
- c. **COLUMN 3: MAINTENANCE FUNCTIONS.** Lists functions to be performed on item listed in Column 2. When items are listed without maintenance functions, it is only to have group numbers in MAC and RPSTL coincide.
- d. **COLUMN 4: MAINTENANCE CATEGORY.** Lists a “work time” figure in the appropriate sub-column(s) to show the lowest level of maintenance authorized to perform the function listed in Column 3. If number or complexity of tasks within limited maintenance function varies at different maintenance categories, appropriate “work time” figures will be shown for each category. Task-hours specified by “work time” figures represent the average time needed to restore a subassembly, module (component or assembly), end item or system to serviceable conditions under typical field operating conditions. The “work time” figure includes preparation time, troubleshooting time and quality assurance/quality control time as well as time required to perform specific tasks identified for maintenance functions authorized in the maintenance allocation chart (MAC). Subcolumns of Column 4 are as follows:
  - C - Operator/Crew
  - O - Organizational
  - F - Direct Support
  - H - General Support
  - D - Depot
- e. **COLUMN 5: TOOLS AND EQUIPMENT.** Specifies by code those common tool sets (not individual tools) and special tools, test and support equipment needed to perform the designated function.
- f. **COLUMN 6: REMARKS.** Contains an alphabetic code leading to the appropriate remark in B-5 (below) for the item opposite each code.

**B-4. TOOLS AND TEST EQUIPMENT REQUIREMENTS**

- a. **TOOL OR TEST EQUIPMENT REFERENCE CODE.** Numbers in this column coincide with numbers used in Column 5 of the MAC and indicate applicable tool or test equipment for maintenance functions.
- b. **MAINTENANCE CATEGORY.** Codes in this column indicate maintenance category allocated the tool or test equipment.
- c. **NOMENCLATURE.** Lists noun name and nomenclature of tools and test equipment needed to perform maintenance functions.
- d. **NATIONAL/NATO STOCK NUMBER.** Lists NATIONAL/NATO stock number of specified tool or test equipment.
- e. **TOOL NUMBER.** Lists manufacturer’s part number of tool, followed by (5 digit) Federal Supply Code for Manufacturers in parentheses.

**B-5. REMARKS**

- a. **REFERENCE CODE.** Refers to appropriate item in Section II, Column 6.
- b. **REMARKS.** Provides necessary information to explain items appearing in Section II.

**Section II. MAINTENANCE ALLOCATION CHART  
FOR  
MD-522A/GRC**

(1) GROUP NUMBER	(2) COMPONENT ASSEMBLY	(3) MAINTENANCE FUNCTION	(4) MAINTENANCE CATEGORY					(5) TOOLS AND EQPT.	(6) REMARKS	
			C	O	F	H	D			
00	MODEM, RADIO TELETYPEWRITER MD-522A/GRC	Inspect	0.2						A B C	
		Inspect		0.3				10		D E F
		Inspect				0.4		9, 11		
		Test	0.2							
		Test		0.5						G
		Test			1.0			1 thru 5, 7, 8, 12 thru 16		
		Test					0.2		1 thru 5, 7, 8, 12 thru 16	
		Service	0.2							A B H
		Service		0.4				10	9, 11	
		Service				0.5				
		Adjust	0.2							I J K
		Adjust		0.3				6	1 thru 5, 7, 9, 11 thru 16	
Adjust				0.4						
Adjust					0.5		1 thru 5, 7, 9, 11 thru 16	L		

**MAINTENANCE ALLOCATION CHART  
FOR  
MD-522A/GRC - continued**

(1) GROUP NUMBER	(2) COMPONENT ASSEMBLY	(3) MAINTENANCE FUNCTION	(4) MAINTENANCE CATEGORY					(5) TOOLS AND EQPT.	(6) REMARKS
			C	O	F	H	D		
01	CHASSIS ASSEMBLY	Install			0.5			9, 11	
		Replace			0.6			9, 11	
		Repair			1.0			9, 11	M
		Repair					3.0	9, 11	N
		Overhaul					5.0	1 thru	O
		Rebuild					10.0	5,7,8,9, 11 thru 27	O
		Inspect	0.2					10	A
		Test		1.0				1 thru	P
		Test				2.0		5, 7, 8, 12 thru 16	Q
								1 thru	
								5, 7, 8, 12 thru 27	



**MAINTENANCE ALLOCATION CHART  
FOR  
MD-522A/GRC - continued**

(1) GROUP NUMBER	(2) COMPONENT ASSEMBLY	(3) MAINTENANCE FUNCTION	(4) MAINTENANCE CATEGORY					(5) TOOLS AND EQPT.	(6) REMARKS
			C	O	F	H	D		
0101	RECEIVER AUDIO, BFO, + 20V REGULATOR MODULE	Service Adjust	0.3	1.0				1 thru 5, 7, 8, 13, 14, 15, 16	R S
		Adjust			2.0			1 thru 5, 7, 8, 13, 14, 15, 16	T
		Repair Repair Overhaul			0.5		2.0 4.0	9, 11 9, 11 1 thru 5,7,8,9, 11 thru 27	U N O
		Inspect Test		0.2	0.5			10 1 thru 5, 6, 8, 12 thru 16	A Q
		Test					1.0	1 thru 5, 7, 8, 12 thru 27	G

**MAINTENANCE ALLOCATION CHART  
FOR  
MD-522A/GRC - continued**

(1) GROUP NUMBER	(2) COMPONENT ASSEMBLY	(3) MAINTENANCE FUNCTION	(4) MAINTENANCE CATEGORY					(5) TOOLS AND EQPT.	(6) REMARKS
			C	O	F	H	D		
0102	SCOPE MODULE	Service		0.3				10	R
		Replace			0.3			9, 11	
		Adjust			0.5			1 thru 5, 7, 8, 15, 16	BB
		Adjust					0.5	1 thru 5, 7, 8, 11 thru 27	T
		Repair Overhaul					2.0 4.0	9, 11 1 thru 5,7,8,9, 11 thru 27	N O
		Rebuild					8.0 1 thru 5,7,8,9, 11 thru 27	O	
		Inspect Test		0.2	0.5			10 1 thru 5, 7, 8, 12 thru 16	CC

**MAINTENANCE ALLOCATION CHART  
FOR  
MD-522A/GRC - continued**

(1) GROUP NUMBER	(2) COMPONENT ASSEMBLY	(3) MAINTENANCE FUNCTION	(4) MAINTENANCE CATEGORY					(5) TOOLS AND EQPT.	(6) REMARKS
			C	O	F	H	D		
0103	TRANSMITTER MODULE	Test					1.0	1 thru 5,7,8,12, thru 27	Q
		Service Adjust		0.2			0.5	10 1 thru 5,7,8,11, 12 thru 27	R T
		Replace Repair Overhaul			0.3		2.0 4.0	9, 11 9, 11 1 thru 5,7,8,9, 11 thru 27	O
		Rebuild					8.0	1 thru 5,7,8,9, 11 thru 27	O
		Inspect Test		0.2		0.5		10 1 thru 5, 7, 8, 12 thru 16	A CC
		Test						0.1	1 thru 5, 7, 8, 12 thru 27

**MAINTENANCE ALLOCATION CHART  
FOR  
MD-522A/GRC - continued**

(1) GROUP NUMBER	(2) COMPONENT ASSEMBLY	(3) MAINTENANCE FUNCTION	(4) MAINTENANCE CATEGORY					(5) TOOLS AND EQPT.	(6) REMARKS
			C	O	F	H	D		
0104	RECEIVER MODULE	Service Adjust		0.2				10 1 thru 5, 7, 8, 11 thru 27	R T
		Replace Repair Overhaul			0.3			2.0 4.0 9, 11 1 thru	O
		Rebuild					8.0	5,7,8,9, 11 thru 27 1 thru	O
		Inspect Test		0.2	0.5			10 1 thru 5,7,8,14 15, 16	A CC
		Test					1.0	1 thru 5, 7, 8, 12 thru 27	D
		Service Adjust		0.2				0.5 10 1 thru 5, 7, 8, 11 thru 27	R T

**MAINTENANCE ALLOCATION CHART  
FOR  
MD-522A/GRC - continued**

(1) GROUP NUMBER	(2) COMPONENT ASSEMBLY	(3) MAINTENANCE FUNCTION	(4) MAINTENANCE CATEGORY					(5) TOOLS AND EQPT.	(6) REMARKS
			C	O	F	H	D		
0105	LOOP BATTERY MODULE	Replace Repair Overhaul			0.3			9, 11 9, 11 1 thru 5,7,8,9, 11 thru 27	O
		Rebuild					8.0 1 thru 5,7,8,9, 11 thru 27	O	
		Inspect Test		0.2	0.5			10 1 thru 5, 7, 8, 12 thru 16	A CC
		Test					1.0 1 thru 5, 7, 8, 12 thru 27	D	
		Service Adjust		0.2			0.5 1 thru 5, 7, 8, 11 thru 27	R T	
		Replace Repair Overhaul			0.3			9, 11 9, 11 1 thru 5,7,8,9, 11 thru 27	O

**MAINTENANCE ALLOCATION CHART  
FOR  
MD-522A/GRC - continued**

(1) GROUP NUMBER	(2) COMPONENT ASSEMBLY	(3) MAINTENANCE FUNCTION	(4) MAINTENANCE CATEGORY					(5) TOOLS AND EQPT.	(6) REMARKS
			C	O	F	H	D		
0106	PANEL ASSEMBLY, FRONT	Rebuild					8.0	1 thru 5,7,8,9, 11 thru 27	O
		Inspect	0.2						A
		Test		0.5				6	V
		Test			1.0			1 thru 5, 7, 8, 12 thru 16	G
		Test				1.0		1 thru 5, 7, 8, 12 thru 16	
		Service	0.2						A
		Service		0.5					W
		Adjust	0.2						X
		Adjust			0.4				Y
		Adjust				0.6			L
Replace		0.2						Z	
Repair				1.0			9, 11	AA	
Repair						2.0	9, 11	N	
Overhaul						4.0	1 thru 5,7,8,9, 11 thru 27	O	

**MAINTENANCE ALLOCATION CHART  
FOR  
MD-522A/GRC - continued**

(1) GROUP NUMBER	(2) COMPONENT ASSEMBLY	(3) MAINTENANCE FUNCTION	(4) MAINTENANCE CATEGORY					(5) TOOLS AND EQPT.	(6) REMARKS
			C	O	F	H	D		
02	CASE ASSEMBLY	Rebuild					8.0	1 thru 5,7 thru 9, 11, 12, thru 27	O
		Inspect	0.1						
		Inspect		0.2				10	
		Service	0.2						A
		Service		0.3				10	C
		Service				0.5		9, 11	
		Repair			1.0			9, 11	
		Overhaul					2.0	9, 11	
Rebuild					4.0	9, 11			

**Section III. TOOL AND TEST EQUIPMENT REQUIREMENTS  
FOR  
MD-522A/GRC**

<b>TOOL OR TEST EQUIPMENT REF CODE</b>	<b>MAINTENANCE CATEGORY</b>	<b>NOMENCLATURE</b>	<b>NATIONAL/NATO STOCK NUMBER</b>	<b>TOOL NUMBER</b>
1	F,H,D	POWER SUPPLY PP-3940/G, OR EQUIVALENT	6130-00-953-7500	
2	F,H,D	OSCILLOSCOPE AN/USM-281A, OR EQUIVALENT	6625-00-228-2201	
3	F,H,D	COUNTER, ELECTRONIC, DIGITAL READOUT AN/USM-207	6625-00-911-6368	
4	F,H,D	GENERATOR, SIGNAL AN/USM- 127	6625-00-783-5965	
5	F,H,D	HANDSET H-33/PT	5965-00-163-9947	
6	O	MULTIMETER AN/URM-105	6625-00-581-2036	
7	F,H,D	MULTIMETER ME-26( )/U	6625-00-646-9409	
8	F,H,D	MULTIMETER TS-352B/U	6625-00-553-0142	
9	F,H,D	TOOL KIT, ELECTRONIC EQUIPMENT TK-100/G	5180-00-605-0079	
10	O	TOOL KIT, ELECTRONIC EQUIPMENT TK-101/G	5180-00-064-5178	
11	F,H,D	TOOL KIT, ELECTRONIC EQUIPMENT TK-105/G	5180-00-610-8177	
12	F,H,D	EXTENDER CABLES NO. 4 AND 5		
13	F,H,D	TEST SET, TELETYPEWRITER AN/ USM-1	6625-00-965-0195	
14	F,H,D	TEST CABLES (6)		
15	F,H,D	VOLTMETER ME-30( )/U	6625-00-643-1670	



**Section III. TOOL AND TEST EQUIPMENT REQUIREMENTS FOR MD-522A/QRC - continued**

TOOL OR TEST EQUIPMENT REF CODE	MAINTENANCE CATEGORY	NOMENCLATURE	NATIONAL/NATO STOCK NUMBER	TOOL NUMBER
16	F,H,D	ELECTRONIC VOLTMETER AN/URM-145	6625-00-973-3986	
17	D	SOUND ANALYZER TS-615A/U, OR EQUIVALENT	6625-00-243-0596	
18	D	SPECTRUM ANALYZER TS-723( )/U	6625-00-668-9418	
19	D	DIFFERENTIAL VOLTMETER ME-202B/U	6625-00-972-4046	
20	D	NOISE GENERATOR, GENERAL RADIO 1390B, OR EQUIVALENT	6625-00-799-8999	
21	D	POWER SUPPLY PP-3135/U	6625-00-635-7991	
22	D	VOLTMETER, HEWLETT-PACKARD NO. 3435A OR EQUIVALENT	6625-01-042-7415	
23	D	AUDIO OSCILLATOR TS-421C/U	6625-00-211-7177	
24	D	WAVE ANALYZER, HEWLETT-PACKARD NO. 302A (TS-1830/U)	6625-00-845-7183	
25	D	POWER AMPLIFIER GENERAL RADIO NO. 1233A	4935-00-448-0150	
26	D	AMPLIFIER, RADIO FREQUENCY AM-1881/U	5895-00-092-7924	
27	D	VARIABLE ELECTRONIC FILTER, SPENCER-KENNEDY LAB INC. MODEL 300, OR EQUIVALENT	5915-00-338-2555	

## Section IV. REMARKS

REFERENCE CODE	REMARKS
A	Exterior only.
B	Interior of modem; exterior of modules.
C	All inspections.
D	Operational check only.
E	Quarterly preventive maintenance.
F	Those tests required to locate faulty modules and components mounted on MP1 and MP2.
G	All tests.
H	All servicing.
I	All front panel controls including controls located behind front panel hinged access door.
J	All controls on equipment exterior.
K	All adjustments external to modules.
L	All adjustments.
M	Replacement of modules, circuit boards A6, A7, A8, A9, and components on MP1 and MP2.
N	All repairs.
O	Plus shop support.
P	Those tests required to locate faulty modules and faulty components mounted on chassis.
Q	Tests required to repair faulty modules.
R	Preventive maintenance only.

**Section IV. REMARKS -Continued**

<b>REFERENCE CODE</b>	<b>REMARKS</b>
S	Those adjustments required after replacement of modules and components.
T	Those adjustments after module repair.
U	By replacement of faulty modules and components mounted on chassis.
V	Those tests to locate faulty components and printed circuit boards mounted on front panel.
W	Interior of panel.
X	Operator adjustments only.
Y	All adjustments located on panel.
Z	Front panel knobs.
AA	By replacement of circuit boards A6, A7, A8, and A9, and components mounted on panel.
BB	Those adjustments required after module replacement.
CC	Those tests required to locate faulty module.



## APPENDIX C

## EXPENDABLE SUPPLIES AND MATERIALS LIST

## Section I. INTRODUCTION

## C-1. GENERAL INFORMATION

This appendix lists expendable supplies and materials you will need to operate and maintain MD-522A/GRC. These items are authorized to you by CTA 50-970, Expendable Items.

## C-2. EXPLANATION OF COLUMNS

- a. **ITEM NO.** This number is referenced in the narrative instructions to identify the material (for example, "Use cleaning compound, Item 9, App. C").
- b. **LEVEL.** Shows the lowest level of maintenance that needs the listed item. Enter as applicable:  
C - Crew/Operator  
O - Organizational Maintenance
- c. **NATIONAL STOCK NUMBER.** Shows the National Stock Number assigned to each item and used to requisition that item.
- d. **DESCRIPTION.** Shows the National Item Name and (if required) a short description to identify and locate the item. The last line for each item shows the Federal Supply Code for Manufacturers (FSCM) in parentheses, followed by the part number.
- e. **UNIT OF MEASURE (U/M).** Shows the measure of the item needed to perform the actual operational/maintenance function. This measure is shown by a two-letter abbreviation (for example, EA, OZ, IN).

## EXPENDABLE SUPPLIES AND MATERIALS LIST

ITEM NO.	LEVEL	NATIONAL STOCK NUMBER	DESCRIPTION	U/M
1	0	8040-00-691-6134	Cement, 3M Co. EC-847 (76381)	OZ
2	0	6850-00-105-3084	Cleaning compound	OZ
3	0	8305-00-267-3015	Cloth, cheese cloth (81348)	YD
4	0		Sandpaper, No. 0000	SH
5	0	7920-00-178-8315	2 3/4" long bristle brush	EA
6	0	7930-01-055-6121	Detergent, GP, Liq	GL



## GLOSSARY

audio . . . . .	Frequencies that are heard.
auxiliary . . . . .	Any item not directly a part of a specific component or system but required for its functional operation.
chassis . . . . .	The metal framework on which the parts of the modem are mounted.
coarse tune . . . . .	To tune the signal within a "ballpark" range for fine tuning.
demodulator . . . . .	A device used to convert audio tones into dc mark and space pulses.
dc . . . . .	Electric current (waves) that flows in only one direction and remains essentially constant in magnitude.
intensity . . . . .	A term used to designate brightness or luminance of the spot.
modulator . . . . .	A device used to convert direct current (dc) mark and space pulses into audio tones.
polarity . . . . .	Having two opposite charges - one positive, one negative.
pony loop circuit . . . . .	Allows teletypewriter order wire transmission and reception over landlines from a remote station when system is not operating in the duplex mode.
remote . . . . .	Control indirectly or from a distance.
single channel . . . . .	Use of one frequency for transmission and reception.
stabilize . . . . .	To hold steady.





## INDEX

SUBJECT	PAGE	SUBJECT	PAGE
<b>A</b>		<b>L</b>	
Adjustment	2-6	Lists, components	1-1
Adjustments, preliminary:	2-6	Location of major components	1-2
Loop current internal - external switch	2-6	Loop:	
Transmit NORM/REV switch	2-7	Battery module A5	2-6
		Internal - external switch	2-6
<b>C</b>		<b>M</b>	
Chassis, main:		Major components, location of	1-2
Removal	2-20	Materials, tools, test equipment:	
Replacement	2-24	for Installation	2-1
Checking unpacked equipment	2-1	for PMCS	2-7
Cleaning	2-22	Module:	
Components, list	1-1	A3, transmitter	2-7
Connections	2-3	A5, loop battery	2-6
Cross-reference list, nomenclature	1-1	Modules, removal and replacement	2-22
		Mounting procedure	2-3
<b>D</b>		<b>N</b>	
Data and description, equipment	1-2	Nomenclature cross-reference list	1-1
DC:			
Loop no. 1	2-6	<b>P</b>	
Loop no. 2	2-6	Painting	2-24
Destruction of Army materiel	1-1	Preliminary servicing and adjustment	2-6
		Preparing for storage and shipment	2-25
<b>E</b>		Preventive maintenance checks and services (PMCS)	2-7
Equipment data and description	1-2	Table	2-10
		Principles of operation, technical	1-2
<b>F</b>		Purpose of equipment	1-1
Forms, records, reports	1-1		
Front panel gasket	2-23	<b>R</b>	
		Records, reports, forms	1-1
<b>G</b>		Removal:	
Gasket, front panel:		Main chassis from case	2-20
Replacement procedure	2-23	Modules	2-22
		Reports, forms, records	1-1
<b>I</b>		<b>S</b>	
Installation:		Scope	1-1
Tools required	2-1	Switch:	
Inspection and service	2-20	Loop current internal - external	2-6
Internal-external switch adjustment	2-6	Transmit NORM/REV	2-7

## INDEX - continued

Subject	PAGE
<b>T</b>	
Table:	
PMCS	2-7
Troubleshooting	2-13
Technical principles of operation	1-2
Testing	2-24
Tools, test equipment, materials:	
for Installation	2-1
for PMCS	2-7
Transmit NORM/REV switch adjustment	2-7
Transmitter:	
Module A3	2-7
Troubleshooting:	
Table	2-13
<b>U</b>	
Unpacking	2-1

RECOMMENDED CHANGES TO EQUIPMENT TECHNICAL MANUALS



**SOMETHING WRONG WITH THIS MANUAL?**

THEN... JOT DOWN THE DOPE ABOUT IT ON THIS FORM, TEAR IT OUT, FOLD IT AND DROP IT IN THE MAIL!

FROM: (YOUR UNIT'S COMPLETE ADDRESS)

Commander  
Stateside Army Depot  
ATTN: AMSTA-US  
Stateside, N.J. 07703

DATE 10 July 1975

PUBLICATION NUMBER

TM 11-5840-340-12

DATE

23 Jan 74

TITLE

Radar Set AN/PSC-76

BE EXACT... PIN-POINT WHERE IT IS

IN THIS SPACE TELL WHAT IS WRONG AND WHAT SHOULD BE DONE ABOUT IT:

PAGE NO.	PARA-GRAPH	FIGURE NO.	TABLE NO.
----------	------------	------------	-----------

2-25	2-28		
3-10	3-3		3-1
5-6	5-8		

Recommend that the installation antenna alignment procedure be changed through to specify a 2° IFF antenna lag rather than 1°.

REASON: Experience has shown that with only a 1° lag, the antenna servo system is too sensitive to wind gusting in excess of 20 knots, and has a tendency to rapidly accelerate and decelerate as it hunts, causing strain to the drive train. Hunting is minimized by adjusting the lag to 2° without degradation of operation.

Item 5, Function column. Change "2 db" to "3db."

REASON: The adjustment procedure for the TRANS POWER FAULT indicator calls for a 3 db (500 watts) adjustment to light the TRANS POWER FAULT indicator.

Add new step f.1 to read, "Replace cover plate removed in step e.1, above."

REASON: To replace the cover plate.

FO3

Zone C 3. On J1-2, change "+24 VDC to "+5 VDC."

REASON: This is the output line of the 5 VDC power supply. + 24 VDC is the input voltage.

TEAR ALONG DOTTED LINE

TYPED NAME, GRADE OR TITLE, AND TELEPHONE NUMBER

SSG I. M. DeSpirito 999-1776

SIGN HERE:

*SSG I. M. DeSpirito*

DA FORM 2028-2  
1 AUG 74

P.S.--IF YOUR OUTFIT WANTS TO KNOW ABOUT YOUR MANUAL "FIND" MAKE A CARBON COPY OF THIS AND GIVE IT TO YOUR HEADQUARTERS.

FILL IN YOUR  
UNIT'S ADDRESS

FOLD BACK

DEPARTMENT OF THE ARMY

\_\_\_\_\_  
\_\_\_\_\_

OFFICIAL BUSINESS  
PENALTY FOR PRIVATE USE \$300

POSTAGE AND FEES PAID  
DEPARTMENT OF THE ARMY  
DOD 314



**SAMPLE**

Commander  
US Army Communications-Electronics Command  
and Fort Monmouth  
ATTN: DRSEL-ME-MP  
Fort Monmouth, New Jersey 07703

TEAR ALONG PERFORATED LINE



FILL IN YOUR  
UNIT'S ADDRESS



FOLD BACK

DEPARTMENT OF THE ARMY

---

---

Commander  
US Army Communications-Electronics Command  
and Fort Monmouth, ATTN: DRSEL-ME-MP,  
Fort Monmouth, New Jersey 07703

FOLD BACK

TEAR ALONG DOTTED LINE



FILL IN YOUR  
UNIT'S ADDRESS



FOLD BACK

DEPARTMENT OF THE ARMY

---

---

TEAR ALONG PERFORATED LINE

Commander  
US Army Communications-Electronics Command  
and Fort Monmouth  
ATTN: DRSEL-ME-MP  
Fort Monmouth, New Jersey 07703



RECOMMENDED CHANGES TO EQUIPMENT TECHNICAL PUBLICATIONS



THEN...JOT DOWN THE DOPE ABOUT IT ON THIS FORM. CAREFULLY TEAR IT OUT, FOLD IT AND DROP IT IN THE MAIL.

SOMETHING WRONG WITH THIS PUBLICATION?

FROM: (PRINT YOUR UNIT'S COMPLETE ADDRESS)

DATE SENT

PUBLICATION NUMBER

TM 11-5805-387-20-2

PUBLICATION DATE

5 April 84

PUBLICATION TITLE Modem Radio

Teletypewriter MD-522A/GRC

BE EXACT PIN-POINT WHERE IT IS

PAGE NO.

PARA-GRAPH

FIGURE NO.

TABLE NO.

IN THIS SPACE TELL WHAT IS WRONG AND WHAT SHOULD BE DONE ABOUT IT:

TEAR ALONG PERFORATED LINE

PRINTED NAME GRADE OR TITLE AND TELEPHONE NUMBER

SIGN HERE

DA FORM 1 JUL 79 2028-2

PREVIOUS EDITIONS ARE OBSOLETE

P.S.--IF YOUR OUTFIT WANTS TO KNOW ABOUT YOUR RECOMMENDATION MAKE A CARBON COPY OF THIS AND GIVE IT TO YOUR HEADQUARTERS.

FILL IN YOUR  
UNIT'S ADDRESS

FOLD BACK

DEPARTMENT OF THE ARMY

Commander  
US Army Communications-Electronics Command  
and Fort Monmouth, ATTN: DRSEL-ME-MP,  
Fort Monmouth, New Jersey 07703

FOLD BACK

TEAR ALONG DOTTED LINE

**By Order of the Secretary of the Army:**

**JOHN A. WICKHAM JR.**  
*General, United States Army*  
*Chief of Staff*

**Official:**

**ROBERT M. JOYCE**  
*Major General, United States Army*  
*The Adjutant General*

**DISTRIBUTION:**

To be distributed in accordance with DA FORM 12-51 requirements for MD-522/GRC.





